

# ARTFORMS PANEL SYSTEM • IDEA BOOK





# TABLE OF CONTENTS

ARTFORMS • PANEL SYSTEM



Click on the application of your choice to see the detail page 



# 1. BENCH & PLANTER

ARTFORMS • PANEL SYSTEM



## INTERIOR VIEW

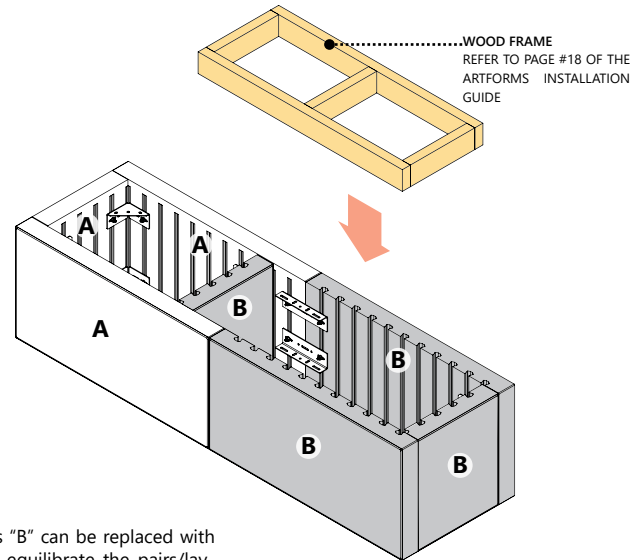

**NOTE:** Panels "B" can be replaced with panels "A" to equilibrate the pairs/layers. Panels "A" can't be replaced by the panels "B".

## REQUIRED PANELS

	18" x 36" PANEL	<b>3x</b>
	18" x 36" PANEL	<b>3x</b>
	6" x 36" PANEL	<b>0x</b>
	6" x 36" PANEL	<b>0x</b>

**IMPORTANT:** 18 x 36" panels are sold in pair/layer or in full pallet only. 6 x 36" panels are sold per unit or in layer or in full pallet.

## FRONT VIEW

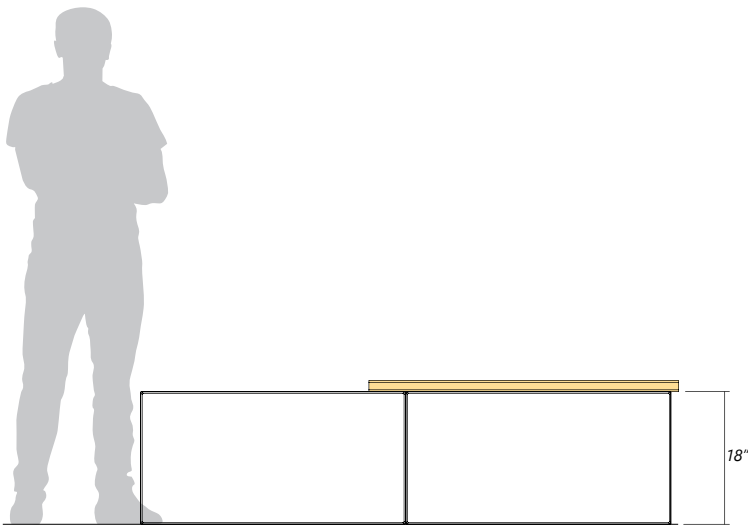

## TOP VIEW

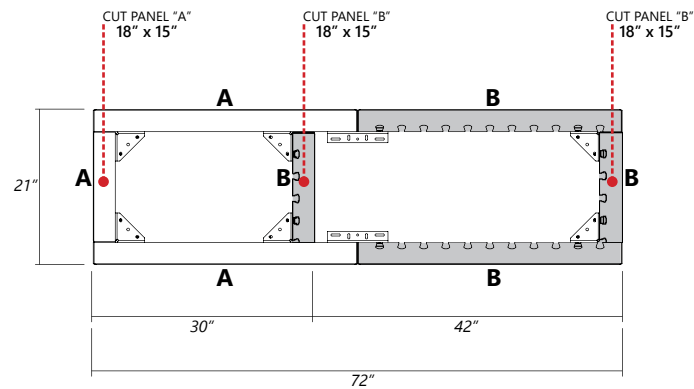

## REQUIRED HARDWARE

	<b>ANCHOR SLIDE AND NUT</b> <b>32x</b> <b>NOTE:</b> Sold only per box (100 units/box)
	<b>JOINING PLATE</b> <b>4x</b> <b>NOTE:</b> Can be sold per box or per unit (40 units/box)
	<b>OUTER CORNER</b> <b>12x</b> <b>NOTE:</b> Can be sold per box or per unit (48 units/box)
	<b>INNER CORNER</b> <b>0x</b> <b>NOTE:</b> Can be sold per box or per unit (24 units/box)
	<b>STRETCHER</b> <b>0x</b> <b>NOTE:</b> Can be sold per box or per unit (10 units/box)

**IMPORTANT:** Refer to page 23 of the ARTFORMS INSTALLATION GUIDE about the installation of geotextile in planter box. Contact experts/engineers to validate the base preparation, the drainage, the plants & roots growth/management.

**TOTAL WEIGHT (PANELS & HARDWARE) 801 Lbs**

# 2. CORNER BENCH AND PLANTER

ARTFORMS • PANEL SYSTEM



INTERIOR VIEW

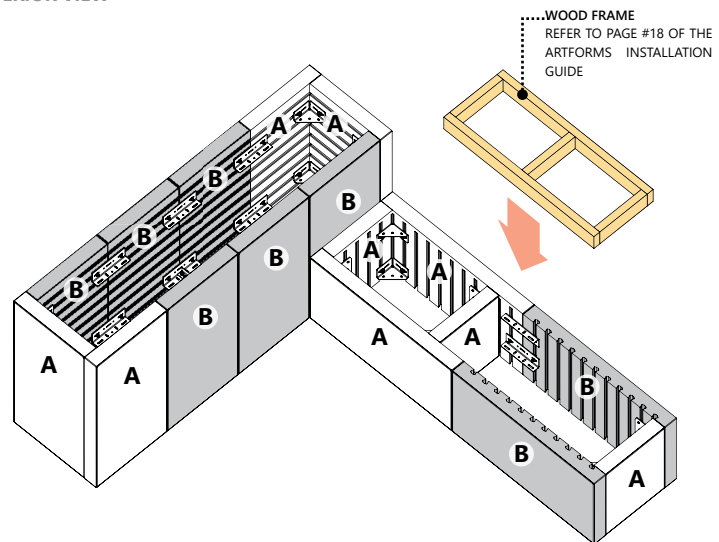

**NOTE:** Panels "B" can be replaced with panels "A" to equilibrate the pairs/layers. Panels "A" can't be replaced by the panels "B".

## REQUIRED PANELS

	18" x 36" PANEL	<b>8x</b>
	18" x 36" PANEL	<b>8x</b>
	6" x 36" PANEL	<b>0x</b>
	6" x 36" PANEL	<b>0x</b>

**IMPORTANT:** 18 x 36" panels are sold in pair/layer or in full pallet only. 6 x 36" panels are sold per unit or in layer or in full pallet.

FRONT VIEW

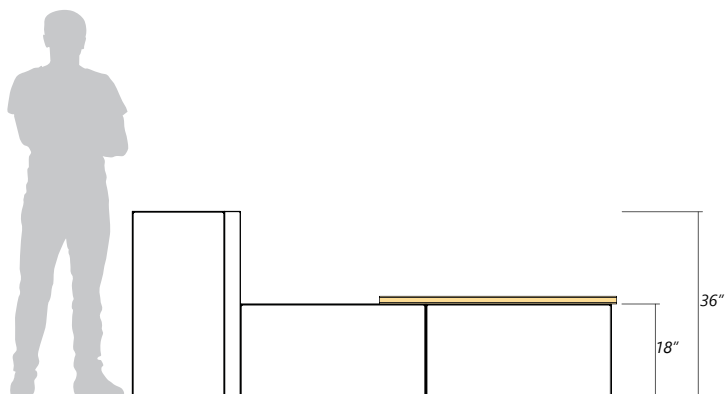

TOP VIEW

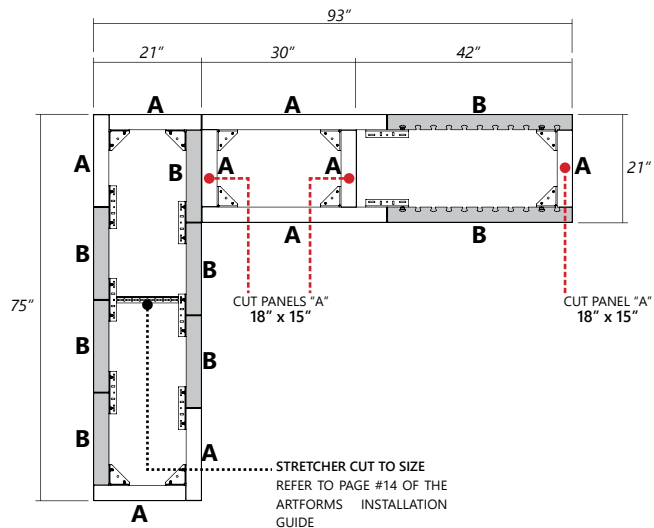

## REQUIRED HARDWARE

	ANCHOR SLIDE AND NUT <b>NOTE:</b> Sold only per box (100 units/box)	<b>74x</b>
	JOINING PLATE <b>NOTE:</b> Can be sold per box or per unit (40 units/box)	<b>16x</b>
	OUTER CORNER <b>NOTE:</b> Can be sold per box or per unit (48 units/box)	<b>20x</b>
	INNER CORNER <b>NOTE:</b> Can be sold per box or per unit (24 units/box)	<b>0x</b>
	STRETCHER <b>NOTE:</b> Can be sold per box or per unit (10 units/box)	<b>1x</b>

**IMPORTANT:** Refer to page 23 of the ARTFORMS INSTALLATION GUIDE about the installation of geotextile in planter box. Contact experts/engineers to validate the base preparation, the drainage, the plants & roots growth/management.

**TOTAL WEIGHT (PANELS & HARDWARE) 2315 Lbs**



# 3. BENCH & VERTICAL PLANTER

ARTFORMS • PANEL SYSTEM



## INTERIOR VIEW

WOOD FRAME .....  
REFER TO PAGE #18 OF THE  
ARTFORMS INSTALLATION  
GUIDE

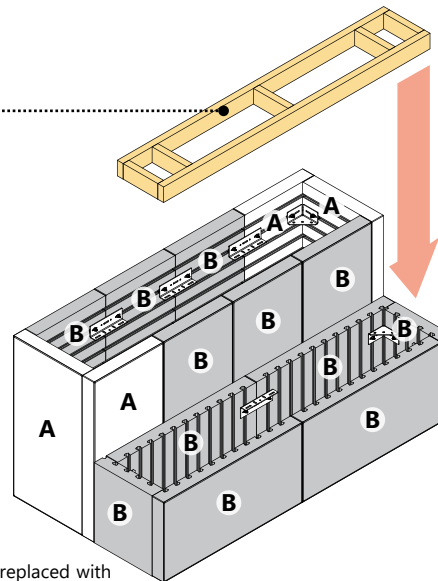

**NOTE :** Panels "B" can be replaced with panels "A" to equilibrate the pairs/layers. Panels "A" can't be replaced by the panels "B".

## REQUIRED PANELS

	18" x 36" PANEL	<b>4x</b>
	18" x 36" PANEL	<b>11x</b>
	6" x 36" PANEL	<b>0x</b>
	6" x 36" PANEL	<b>0x</b>

**IMPORTANT:** 18 x 36" panels are sold in pair/layer or in full pallet only. 6 x 36" panels are sold per unit or in layer or in full pallet.

## FRONT VIEW

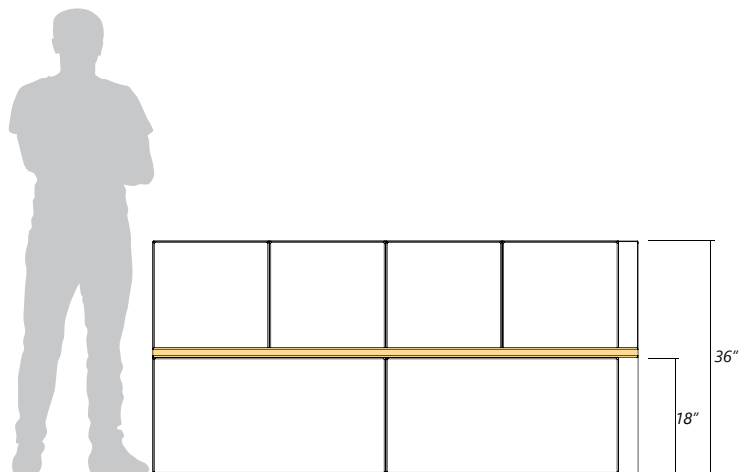

## TOP VIEW

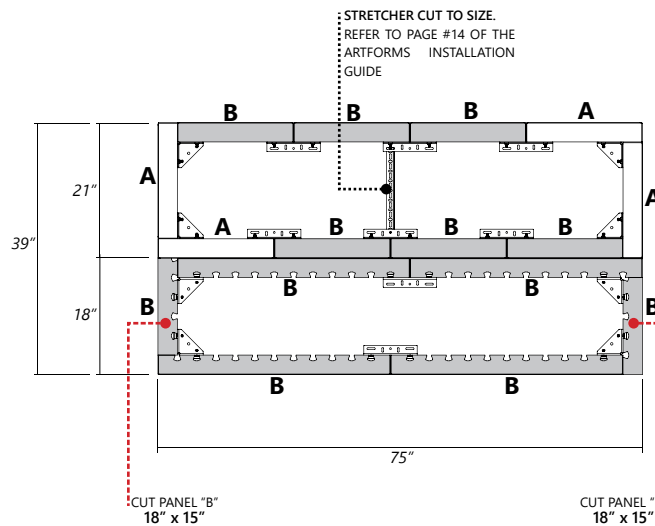

## REQUIRED HARDWARE

	ANCHOR SLIDE AND NUT <b>NOTE:</b> Sold only per box (100 units/box)	<b>66x</b>
	JOINING PLATE <b>NOTE:</b> Can be sold per box or per unit (40 units/box)	<b>16x</b>
	OUTER CORNER <b>NOTE:</b> Can be sold per box or per unit (48 units/box)	<b>16x</b>
	INNER CORNER <b>NOTE:</b> Can be sold per box or per unit (24 units/box)	<b>0x</b>
	STRETCHER <b>NOTE:</b> Can be sold per box or per unit (10 units/box)	<b>1x</b>

**IMPORTANT:** Refer to page 23 of the ARTFORMS INSTALLATION GUIDE about the installation of geotextile in planter box. Contact experts/engineers to validate the base preparation, the drainage, the plants & roots growth/management.

**TOTAL WEIGHT (PANELS & HARDWARE) 2241 Lbs**



INTERIOR VIEW

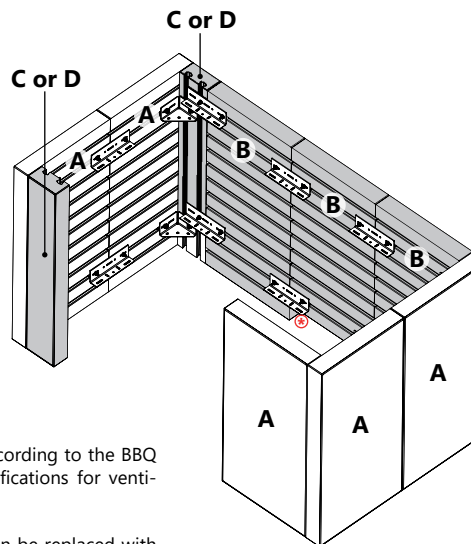

⊗ Cut panel(s) according to the BBQ manufacturer's specifications for ventilation.

**NOTE :** Panels "B" can be replaced with panels "A" to equilibrate the pairs/layers. Panels "A" can't be replaced by the panels "B".

REQUIRED PANELS

- 18" x 36" PANEL **5x**
- 18" x 36" PANEL **3x**
- 6" x 36" PANEL **0x**
- 6" x 36" PANEL **2x**

**IMPORTANT:** 18 x 36" panels are sold in pair/layer or in full pallet only. 6 x 36" panels are sold per unit or in layer or in full pallet.

FRONT VIEW

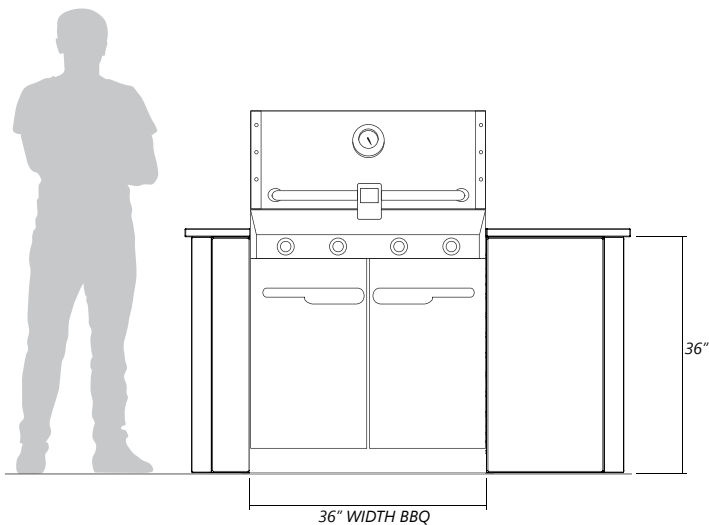

TOP VIEW

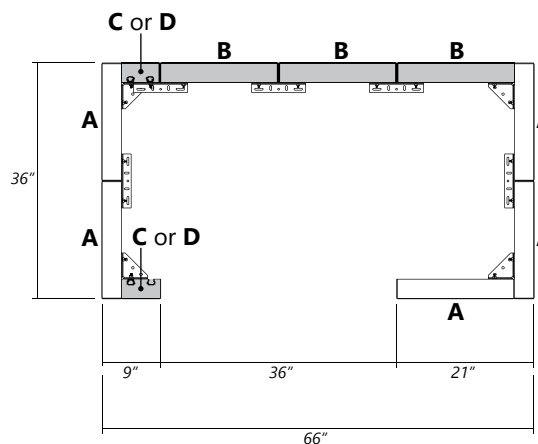

REQUIRED HARDWARE

- ANCHOR SLIDE AND NUT **36x**  
**NOTE:** Sold only per box (100 units/box)
- JOINING PLATE **10x**  
**NOTE:** Can be sold per box or per unit (40 units/box)
- OUTER CORNER **8x**  
**NOTE:** Can be sold per box or per unit (48 units/box)
- INNER CORNER **0x**  
**NOTE:** Can be sold per box or per unit (24 units/box)
- STRETCHER **0x**  
**NOTE:** Can be sold per box or per unit (10 units/box)

**IMPORTANT:** It is recommended to follow the BBQ manufacturer's specifications for ventilation and clearances. Belgard is not responsible for the conformity of connections, clearances and ventilation. BBQ, counter top and accessories are not included.

**TOTAL WEIGHT 1299 Lbs**  
(PANELS & HARDWARE)



# 5. MEDIUM BBQ

ARTFORMS • PANEL SYSTEM



INTERIOR VIEW

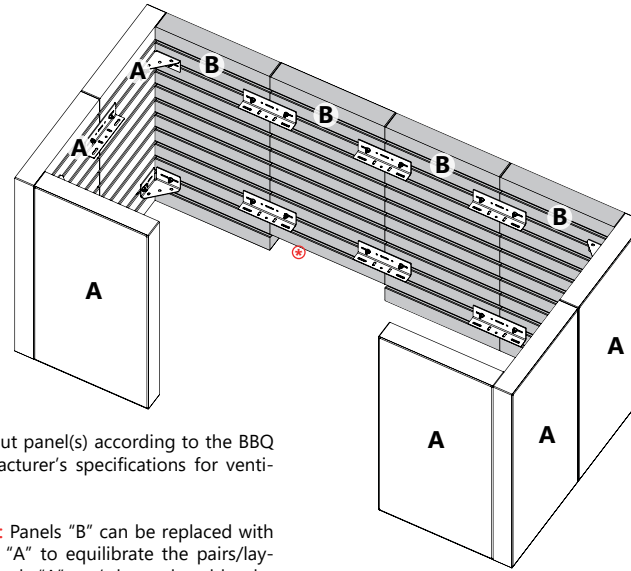

Ⓢ Cut panel(s) according to the BBQ manufacturer's specifications for ventilation.

**NOTE :** Panels "B" can be replaced with panels "A" to equilibrate the pairs/layers. Panels "A" can't be replaced by the panels "B".

**REQUIRED PANELS**

- 18" x 36" PANEL **6x**
- 18" x 36" PANEL **4x**
- 6" x 36" PANEL **0x**
- 6" x 36" PANEL **0x**

**IMPORTANT:** 18 x 36" panels are sold in pair/layer or in full pallet only. 6 x 36" panels are sold per unit or in layer or in full pallet.

FRONT VIEW

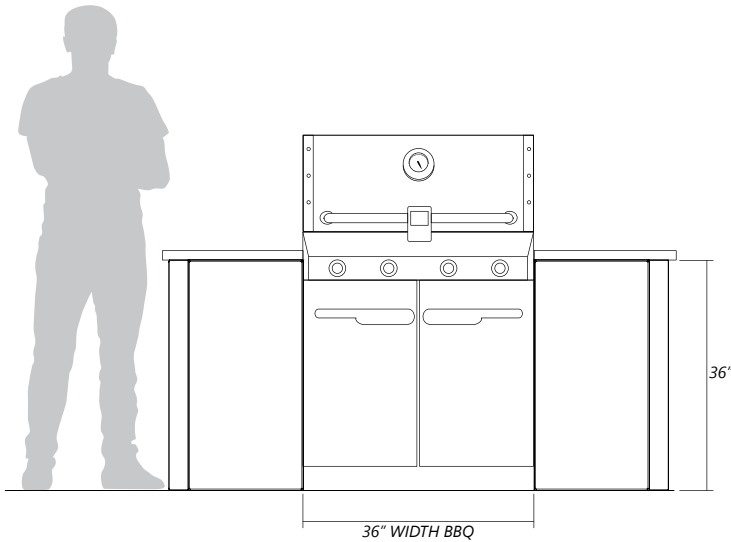

TOP VIEW

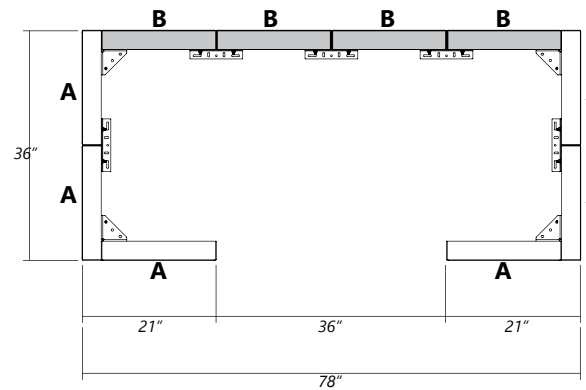

**REQUIRED HARDWARE**

- ANCHOR SLIDE AND NUT **36x**  
**NOTE:** Sold only per box (100 units/box)
- JOINING PLATE **10x**  
**NOTE:** Can be sold per box or per unit (40 units/box)
- OUTER CORNER **8x**  
**NOTE:** Can be sold per box or per unit (48 units/box)
- INNER CORNER **0x**  
**NOTE:** Can be sold per box or per unit (24 units/box)
- STRETCHER **0x**  
**NOTE:** Can be sold per box or per unit (10 units/box)

**IMPORTANT:** It is recommended to follow the BBQ manufacturer's specifications for ventilation and clearances. Belgard is not responsible for the conformity of connections, clearances and ventilation. BBQ, counter top and accessories are not included.

**TOTAL WEIGHT (PANELS & HARDWARE) 1498 Lbs**



INTERIOR VIEW

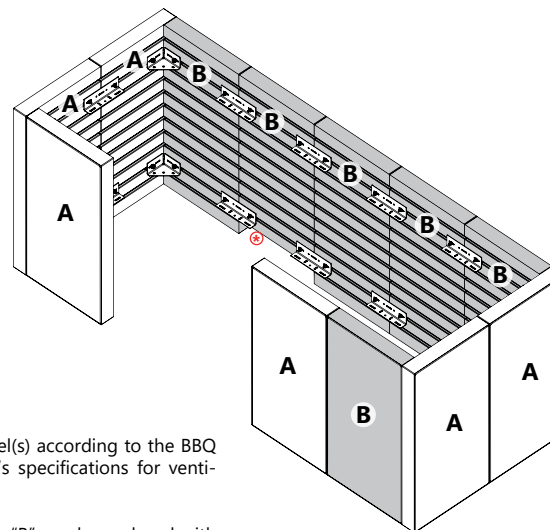

⊗ Cut panel(s) according to the BBQ manufacturer's specifications for ventilation.

**NOTE :** Panels "B" can be replaced with panels "A" to equilibrate the pairs/layers. Panels "A" can't be replaced by the panels "B".

REQUIRED PANELS

- 18" x 36" PANEL **6x**
- 18" x 36" PANEL **6x**
- 6" x 36" PANEL **0x**
- 6" x 36" PANEL **0x**

**IMPORTANT:** 18 x 36" panels are sold in pair/layer or in full pallet only. 6 x 36" panels are sold per unit or in layer or in full pallet.

FRONT VIEW

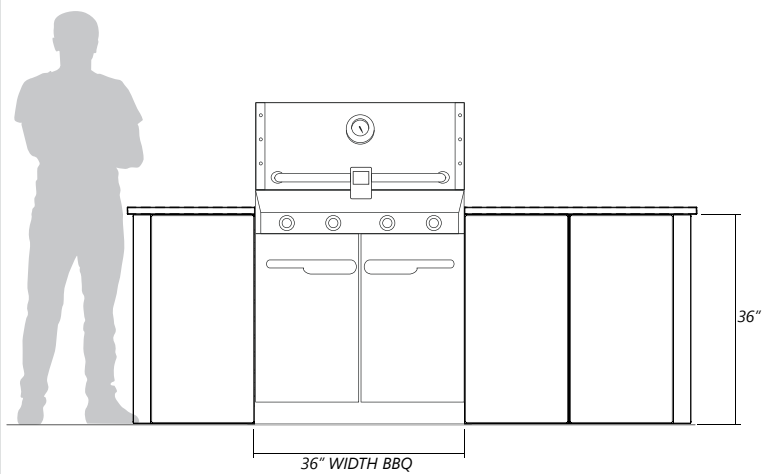

TOP VIEW

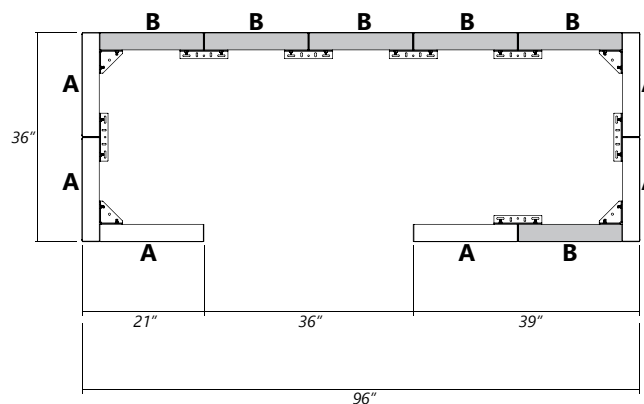

REQUIRED HARDWARE

- 44x**

**ANCHOR SLIDE AND NUT**  
**NOTE:** Sold only per box (100 units/box)
- 14x**

**JOINING PLATE**  
**NOTE:** Can be sold per box or per unit (40 units/box)
- 8x**

**OUTER CORNER**  
**NOTE:** Can be sold per box or per unit (48 units/box)
- 0x**

**INNER CORNER**  
**NOTE:** Can be sold per box or per unit (24 units/box)
- 0x**

**STRETCHER**  
**NOTE:** Can be sold per box or per unit (10 units/box)

**IMPORTANT:** It is recommended to follow the BBQ manufacturer's specifications for ventilation and clearances. Belgard is not responsible for the conformity of connections, clearances and ventilation. BBQ, counter top and accessories are not included.

**TOTAL WEIGHT (PANELS & HARDWARE) 1801 Lbs**



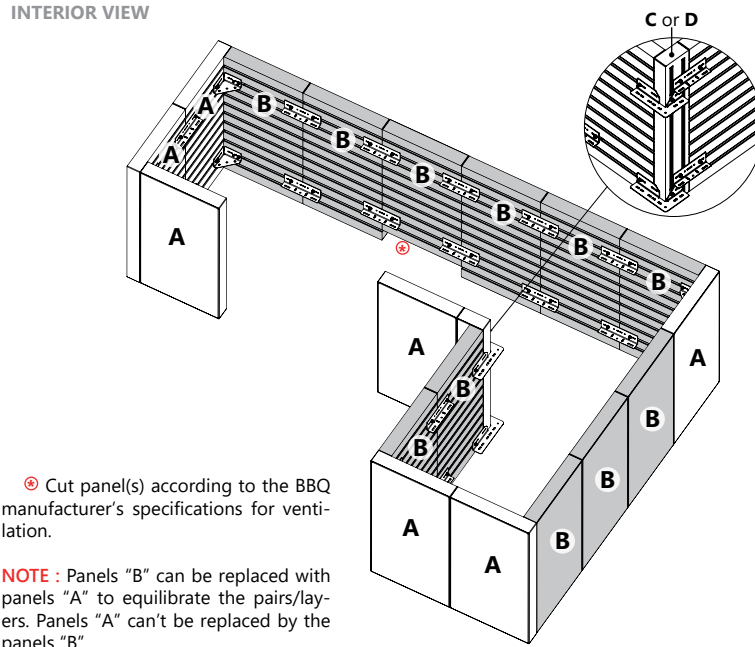

- REQUIRED PANELS**
- 18" x 36" PANEL **7x**
  - 18" x 36" PANEL **11x**
  - 6" x 36" PANEL **1x**
  - 6" x 36" PANEL **0x**

**IMPORTANT:** 18 x 36" panels are sold in pair/layer or in full pallet only. 6 x 36" panels are sold per unit or in layer or in full pallet.

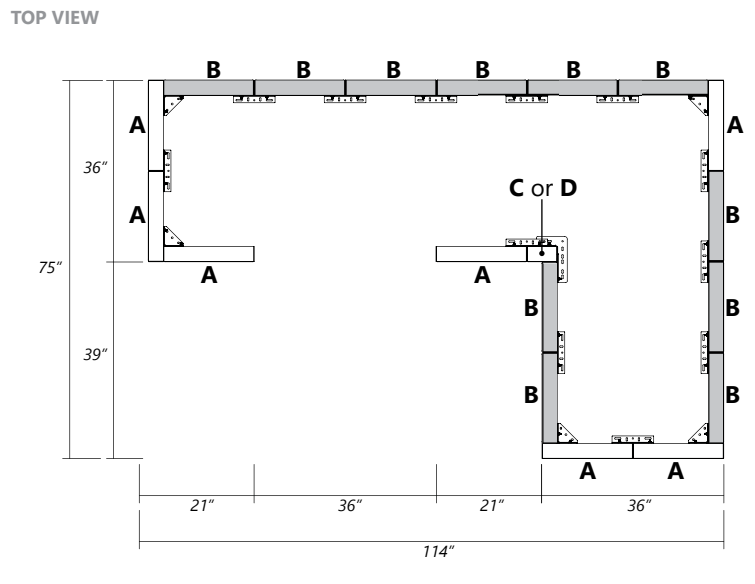
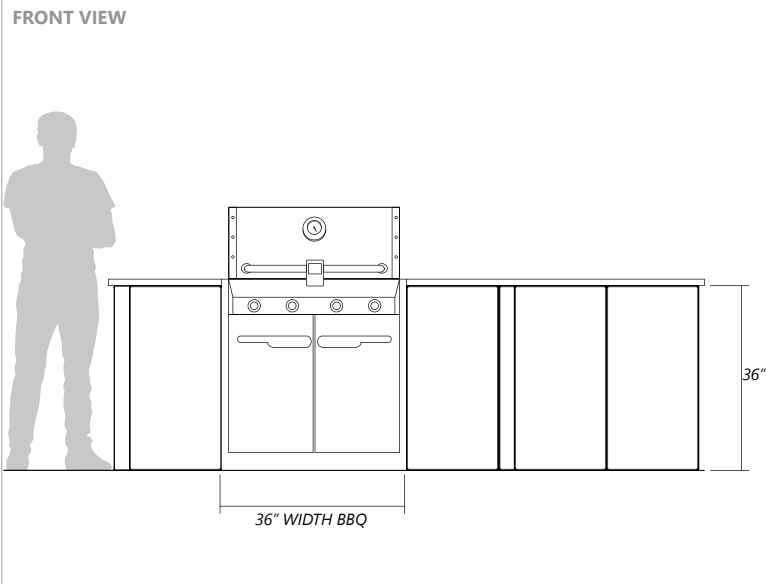

- REQUIRED HARDWARE**
- ANCHOR SLIDE AND NUT **72x**  
**NOTE:** Sold only per box (100 units/box)
  - JOINING PLATE **24x**  
**NOTE:** Can be sold per box or per unit (40 units/box)
  - OUTER CORNER **10x**  
**NOTE:** Can be sold per box or per unit (48 units/box)
  - INNER CORNER **2x**  
**NOTE:** Can be sold per box or per unit (24 units/box)
  - STRETCHER **0x**  
**NOTE:** Can be sold per box or per unit (10 units/box)

**IMPORTANT:** It is recommended to follow the BBQ manufacturer's specifications for ventilation and clearances. Belgard is not responsible for the conformity of connections, clearances and ventilation. BBQ, countertop and accessories are not included.

**TOTAL WEIGHT (PANELS & HARDWARE) 2761 Lbs**

# 8. CORNER BBQ & PIZZA GRILL

ARTFORMS • PANEL SYSTEM

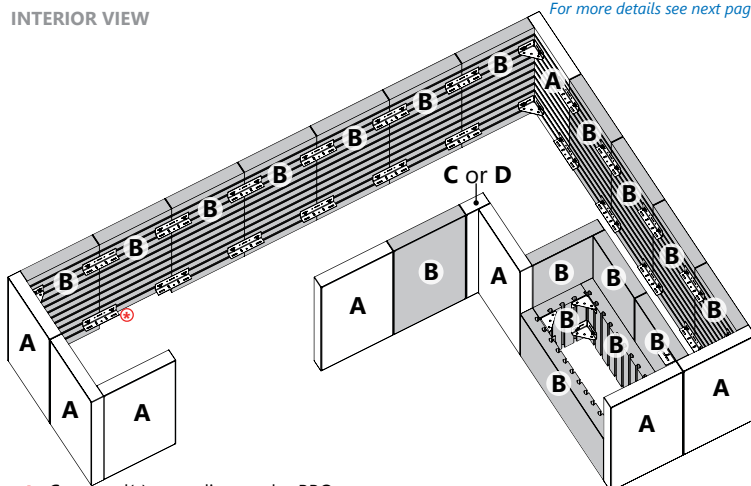

⊗ Cut panel(s) according to the BBQ manufacturer's specifications for ventilation.

**NOTE :** Panels "B" can be replaced with panels "A" to equilibrate the pairs/layers. Panels "A" can't be replaced by the panels "B".

## REQUIRED PANELS

- 18" x 36" PANEL **8x**
- 18" x 36" PANEL **18x**
- 6" x 36" PANEL **1x**
- 6" x 36" PANEL **0x**

**IMPORTANT:** 18 x 36" panels are sold in pair/layer or in full pallet only. 6 x 36" panels are sold per unit or in layer or in full pallet.

## FRONT VIEW

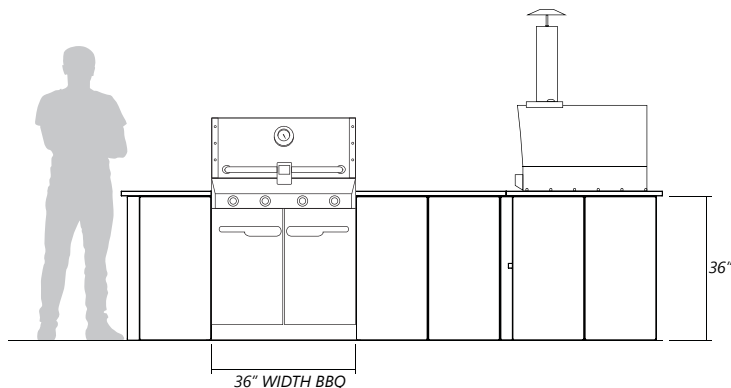

## TOP VIEW

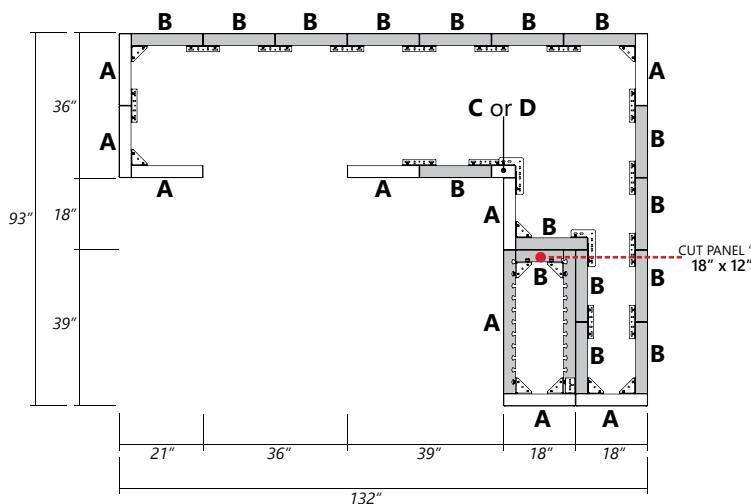

## REQUIRED HARDWARE

- ANCHOR SLIDE AND NUT **106x**  
**NOTE:** Sold only per box (100 units/box)
- JOINING PLATE **28x**  
**NOTE:** Can be sold per box or per unit (40 units/box)
- OUTER CORNER **21x**  
**NOTE:** Can be sold per box or per unit (48 units/box)
- INNER CORNER **4x**  
**NOTE:** Can be sold per box or per unit (24 units/box)
- STRETCHER **0x**  
**NOTE:** Can be sold per box or per unit (10 units/box)

**IMPORTANT:** It is recommended to follow the BBQ manufacturer's specifications for ventilation and clearances. Belgard is not responsible for the conformity of connections, clearances and ventilation. BBQ, countertop and accessories are not included.

**TOTAL WEIGHT (PANELS & HARDWARE) 3872 Lbs**



# 8. CORNER BBQ & PIZZA GRILL

ARTFORMS • PANEL SYSTEM

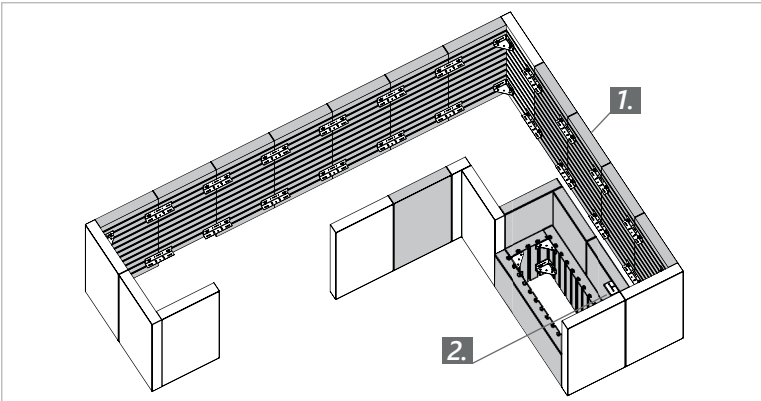

7. INSIDE VIEW OF THE CORNER BBQ & PIZZA GRILL

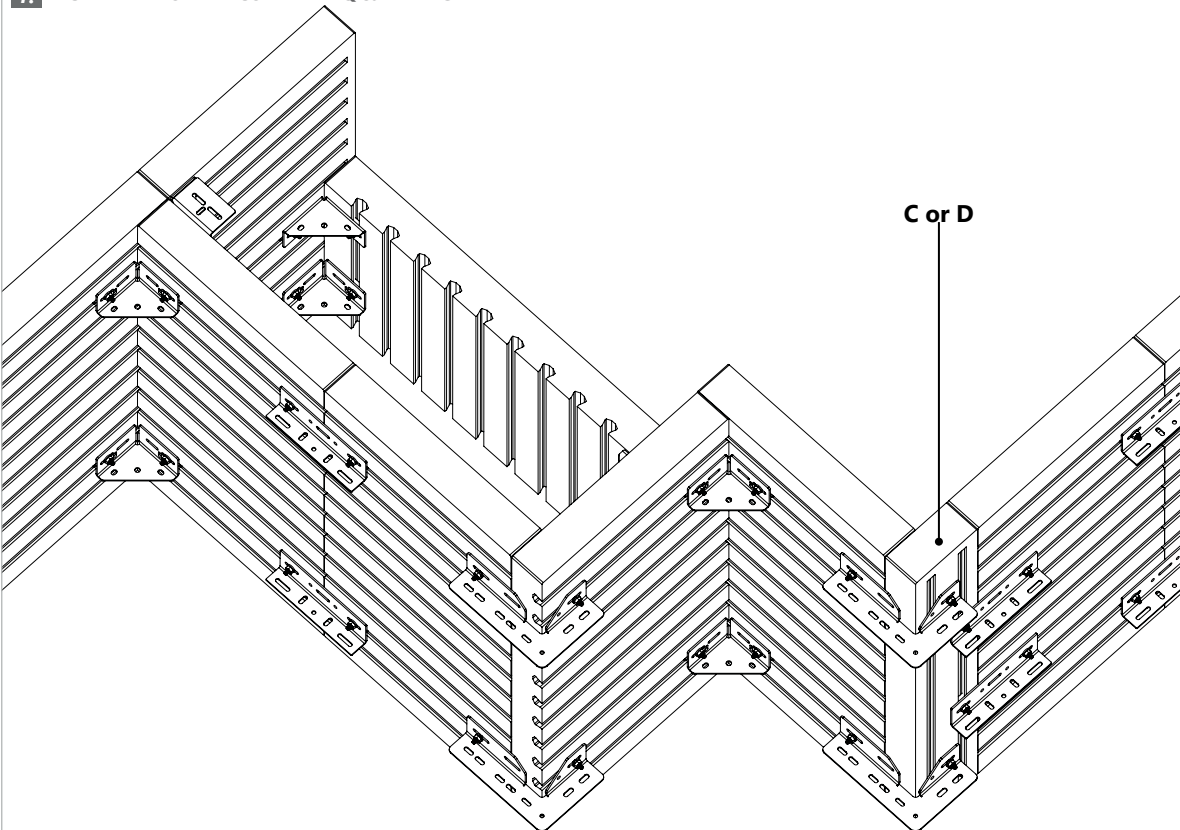

2. INSIDE VIEW OF THE SHELF

NOTE : Y: Treated concrete anchor (Tapcon®)  
1/4"x1 3/4" or 3/16" x 1 3/4"

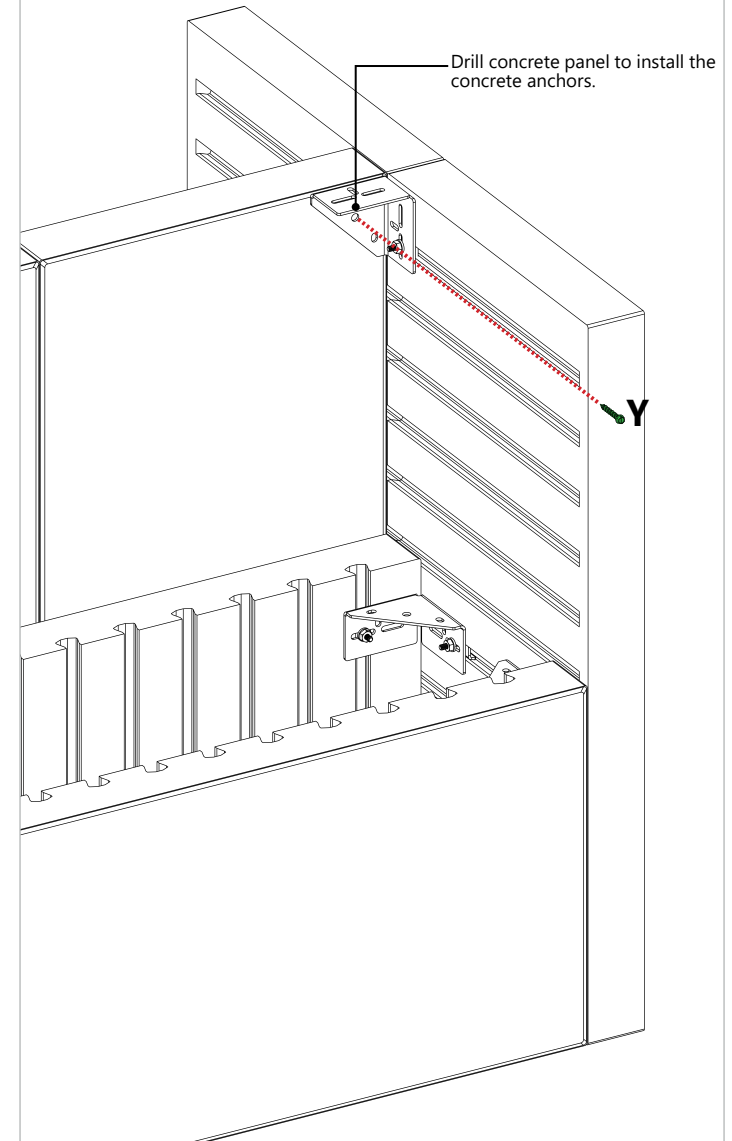

**IMPORTANT:** It is recommended to follow the BBQ manufacturer's specifications for ventilation and clearances. Belgard is not responsible for the conformity of connections, clearances and ventilation. BBQ, countertop and accessories are not included.

# 9. BBQ WITH LUXURY COUNTER & BAR

ARTFORMS • PANEL SYSTEM



FRONT VIEW

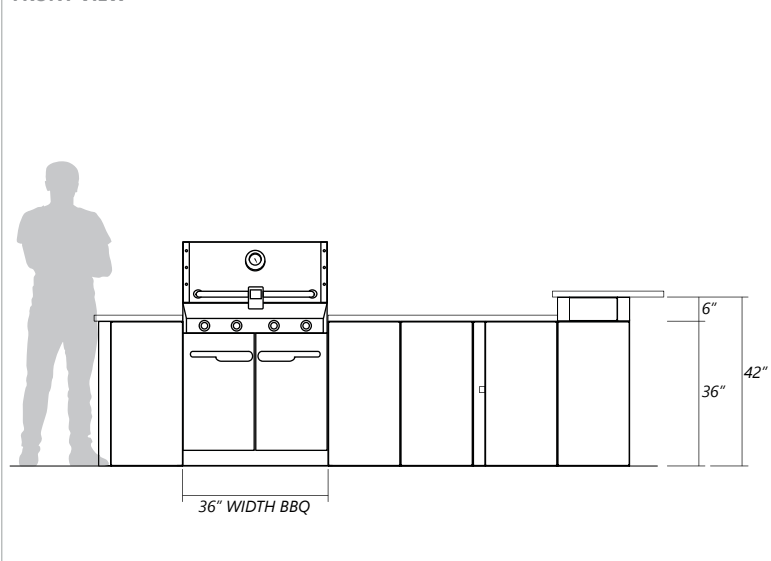

TOP VIEW

18" x 36" PANELS

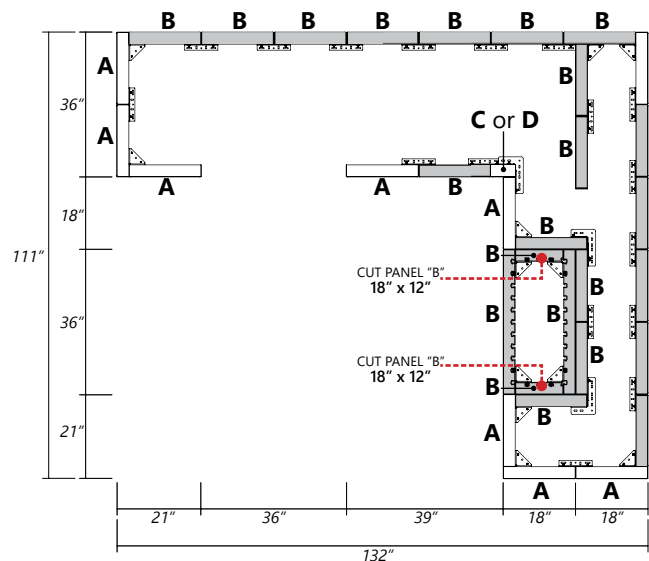

For more details see next page

6" x 36" PANELS

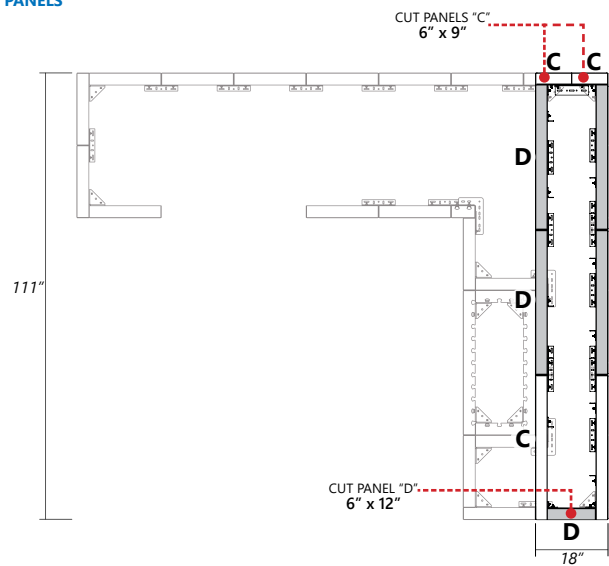

## REQUIRED PANELS

- CLOSED END  
18" x 36" PANEL **9x**
- 18" x 36" PANEL **22x**
- CLOSED END  
6" x 36" PANEL **5x**
- 6" x 36" PANEL **5x**

**IMPORTANT:** 18 x 36" panels are sold in pair/layer or in full pallet only. 6 x 36" panels are sold per unit or in layer or in full pallet.

## REQUIRED HARDWARE

- ANCHOR SLIDE AND NUT **146x**  
*NOTE:* Sold only per box (100 units/box)
- JOINING PLATE **52x**  
*NOTE:* Can be sold per box or per unit (40 units/box)
- OUTER CORNER **22x**  
*NOTE:* Can be sold per box or per unit (48 units/box)
- INNER CORNER **6x**  
*NOTE:* Can be sold per box or per unit (24 units/box)
- STRETCHER **0x**  
*NOTE:* Can be sold per box or per unit (10 units/box)

**IMPORTANT:** It is recommended to follow the BBQ manufacturer's specifications for ventilation and clearances. Belgard is not responsible for the conformity of connections, clearances and ventilation. BBQ, countertop and accessories are not included.

**TOTAL WEIGHT 5036 Lbs**  
(PANELS & HARDWARE)

# 9. BBQ WITH LUXURY COUNTER & BAR

ARTFORMS • PANEL SYSTEM



## EXPLODED VIEW

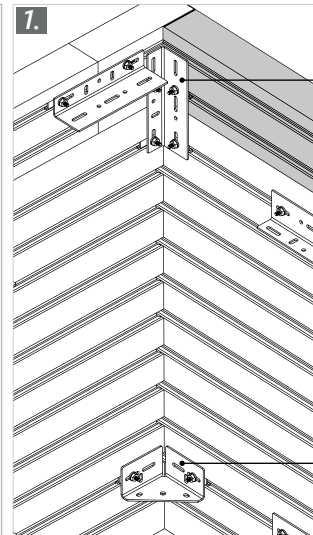
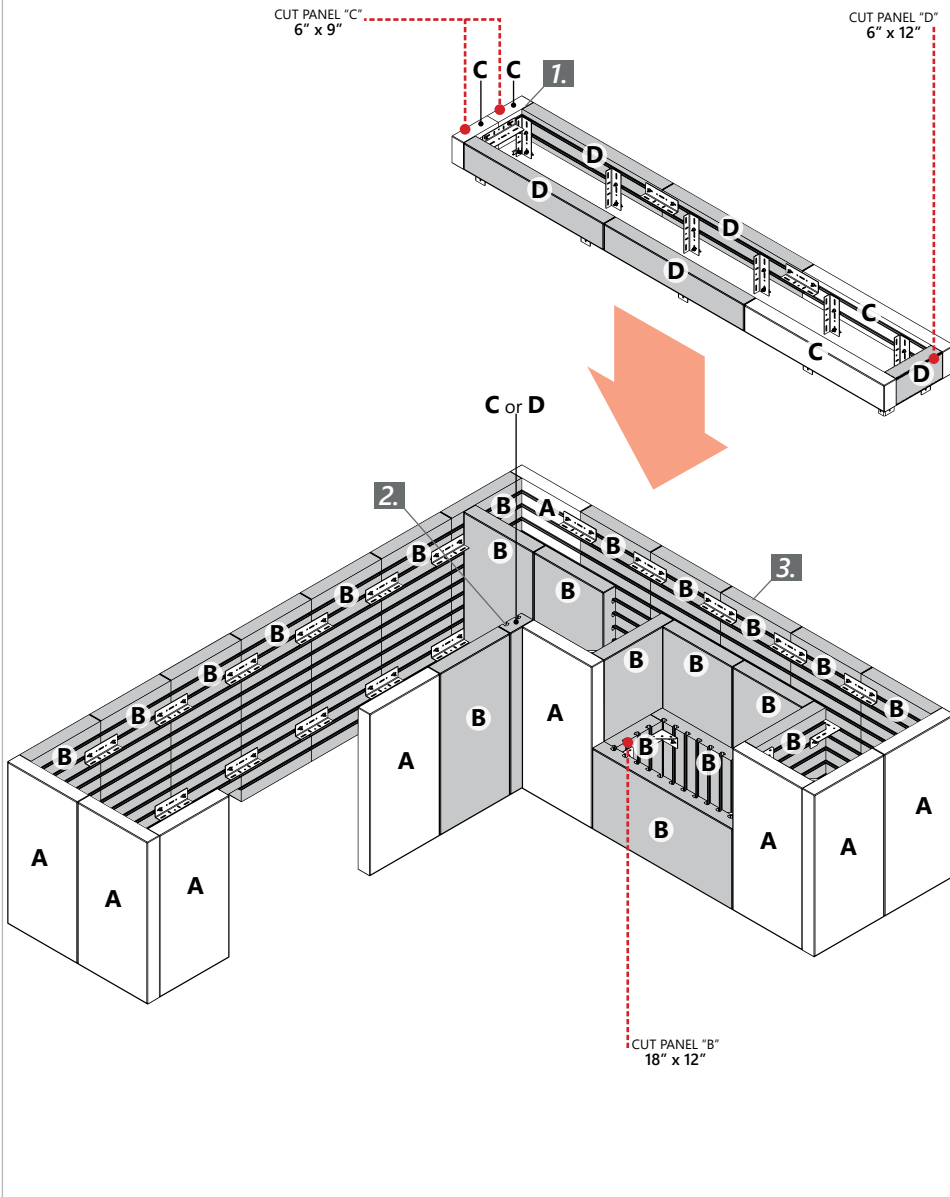

Use a JOINING PLATE for the top corners, to join the 4 panels.

Use an OUTER CORNER for the bottom corners.

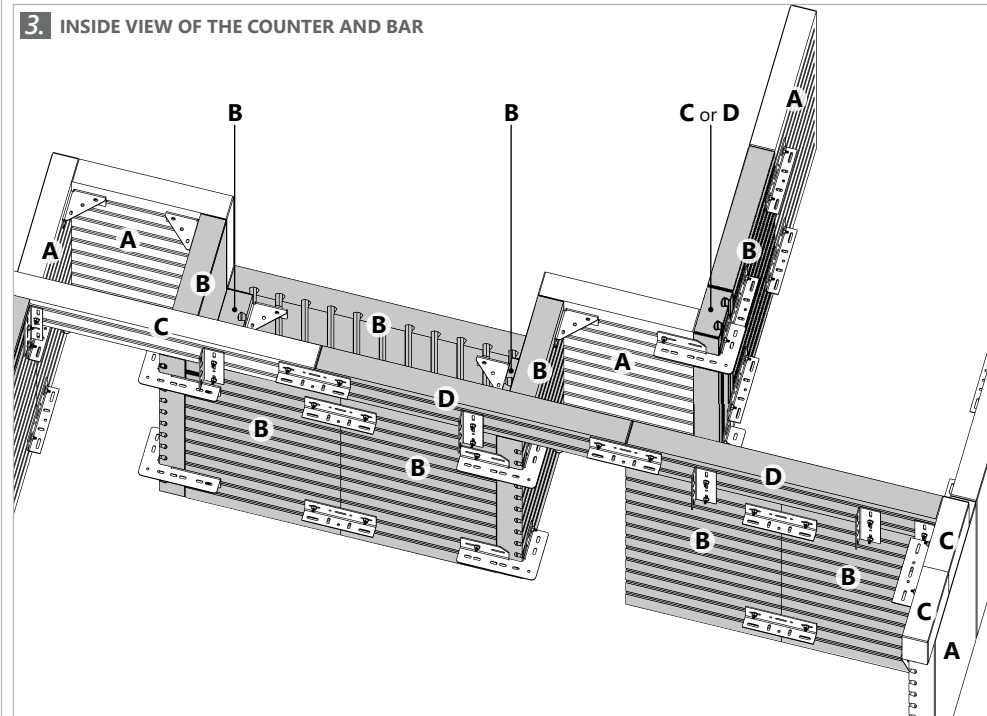
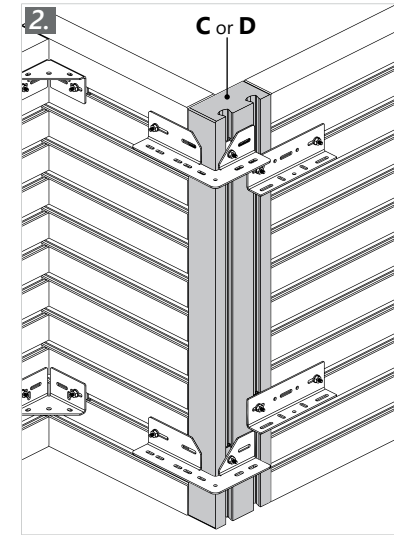

**IMPORTANT:** It is recommended to follow the BBQ manufacturer's specifications for ventilation and clearances. Belgard is not responsible for the conformity of connections, clearances and ventilation. BBQ, countertop and accessories are not included.





INTERIOR VIEW

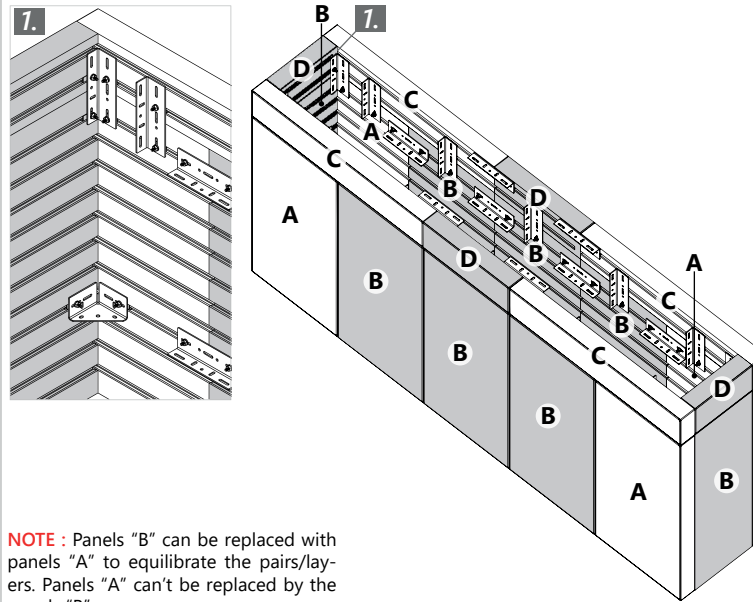

**NOTE :** Panels "B" can be replaced with panels "A" to equilibrate the pairs/layers. Panels "A" can't be replaced by the panels "B".

REQUIRED PANELS

- 4x**
- 8x**
- 4x**
- 3x**

**IMPORTANT:** 18 x 36" panels are sold in pair/layer or in full pallet only. 6 x 36" panels are sold per unit or in layer or in full pallet.

FRONT VIEW

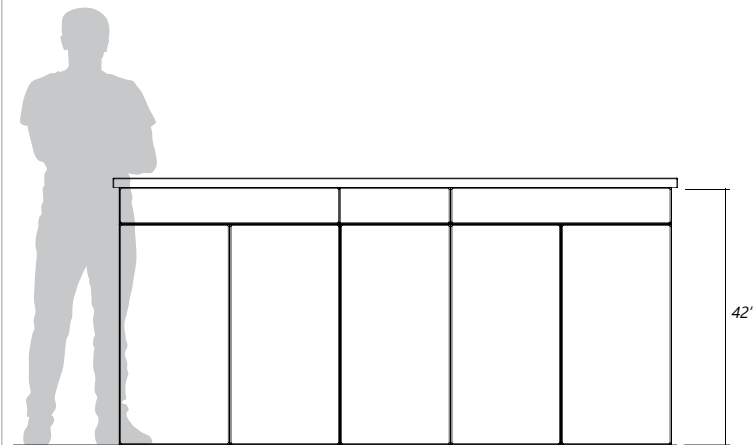

TOP VIEW

18" x 36" PANELS

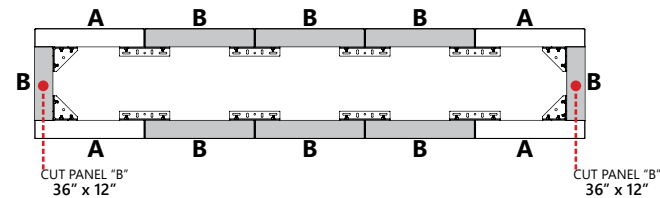

6" x 36" PANELS

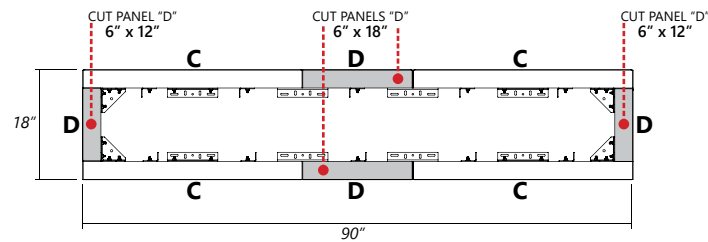

REQUIRED HARDWARE

- 76x**  
**NOTE:** Sold only per box (100 units/box)
- 34x**  
**NOTE:** Can be sold per box or per unit (40 units/box)
- 4x**  
**NOTE:** Can be sold per box or per unit (48 units/box)
- 0x**  
**NOTE:** Can be sold per box or per unit (24 units/box)
- 0x**  
**NOTE:** Can be sold per box or per unit (10 units/box)

**TOTAL WEIGHT 1968 Lbs**  
(PANELS & HARDWARE)



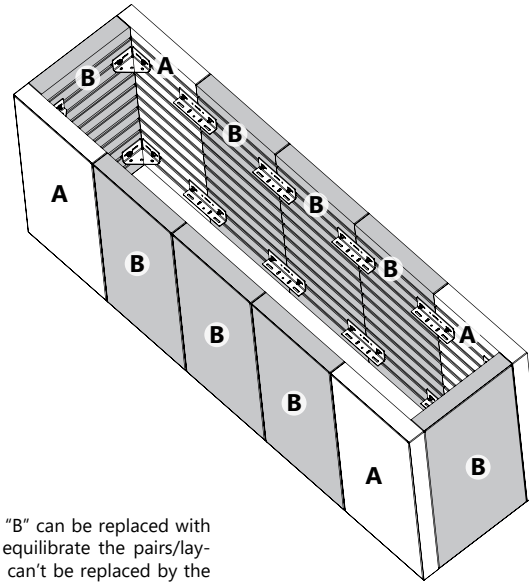

INTERIOR VIEW

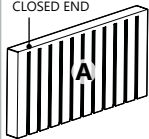
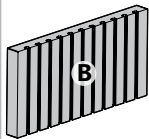
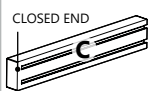

**NOTE :** Panels "B" can be replaced with panels "A" to equilibrate the pairs/layers. Panels "A" can't be replaced by the panels "B".

**REQUIRED PANELS**

-  **18" x 36" PANEL** **4x**
-  **18" x 36" PANEL** **8x**
-  **6" x 36" PANEL** **0x**
-  **6" x 36" PANEL** **0x**

**IMPORTANT:** 18 x 36" panels are sold in pair/layer or in full pallet only. 6 x 36" panels are sold per unit or in layer or in full pallet.

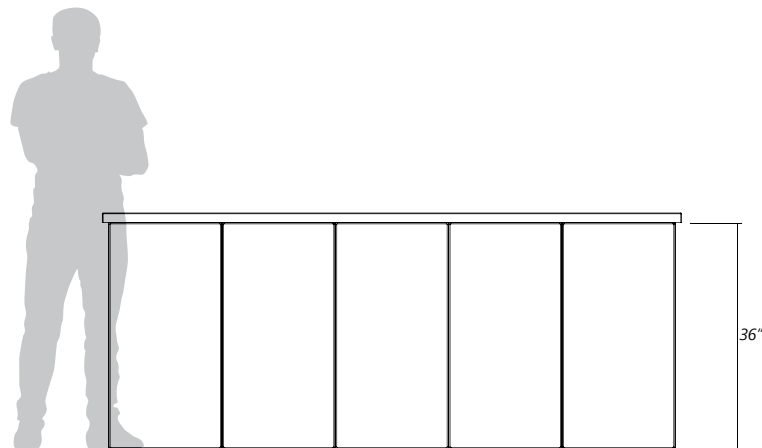

FRONT VIEW

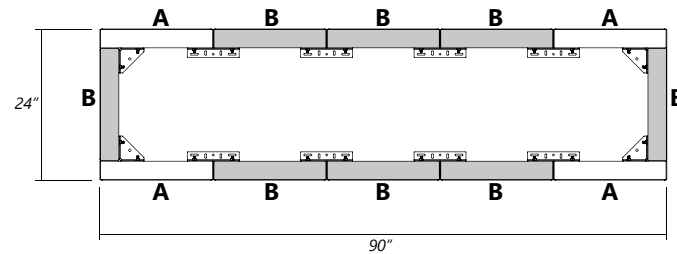

TOP VIEW

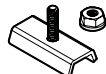
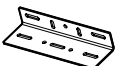
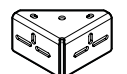

**REQUIRED HARDWARE**

-  **ANCHOR SLIDE AND NUT** **48x**  
**NOTE:** Sold only per box (100 units/box)
-  **JOINING PLATE** **16x**  
**NOTE:** Can be sold per box or per unit (40 units/box)
-  **OUTER CORNER** **8x**  
**NOTE:** Can be sold per box or per unit (48 units/box)
-  **INNER CORNER** **0x**  
**NOTE:** Can be sold per box or per unit (24 units/box)
-  **STRETCHER** **0x**  
**NOTE:** Can be sold per box or per unit (10 units/box)

**TOTAL WEIGHT 1815 Lbs**  
(PANELS & HARDWARE)



INTERIOR VIEW

For more details see next page

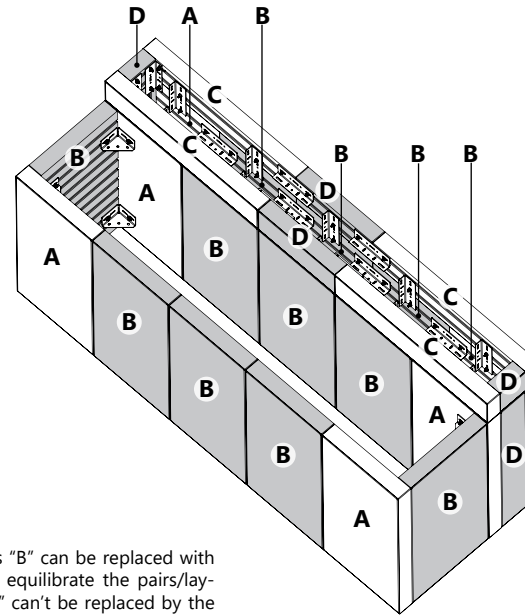

**NOTE :** Panels "B" can be replaced with panels "A" to equilibrate the pairs/layers. Panels "A" can't be replaced by the panels "B".

### REQUIRED PANELS

- 18" x 36" PANEL **6x**
- 18" x 36" PANEL **11x**
- 6" x 36" PANEL **4x**
- 6" x 36" PANEL **5x**

**IMPORTANT:** 18 x 36" panels are sold in pair/layer or in full pallet only. 6 x 36" panels are sold per unit or in layer or in full pallet.

FRONT VIEW

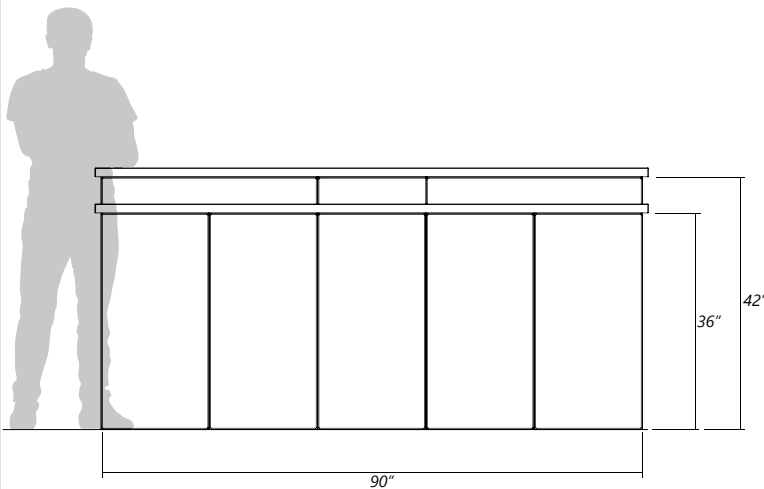

TOP VIEW

18" x 36" PANELS

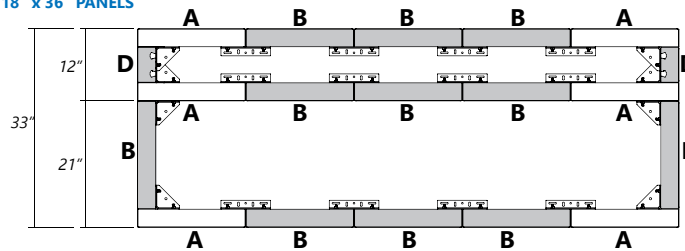

6" x 36" PANELS

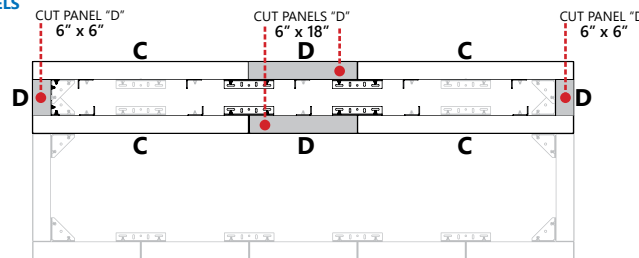

### REQUIRED HARDWARE

- ANCHOR SLIDE AND NUT **108x**  
**NOTE:** Sold only per box (100 units/box)
- JOINING PLATE **42x**  
**NOTE:** Can be sold per box or per unit (40 units/box)
- OUTER CORNER **12x**  
**NOTE:** Can be sold per box or per unit (48 units/box)
- INNER CORNER **0x**  
**NOTE:** Can be sold per box or per unit (24 units/box)
- STRETCHER **0x**  
**NOTE:** Can be sold per box or per unit (10 units/box)

**TOTAL WEIGHT 2934 Lbs**  
(PANELS & HARDWARE)



EXPLODED VIEW

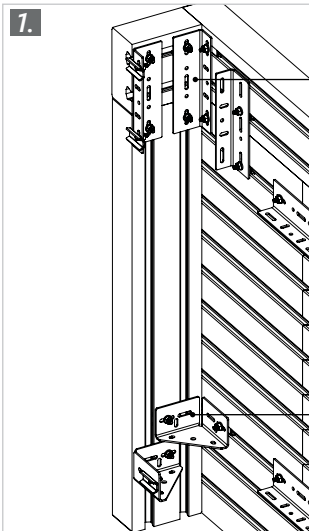
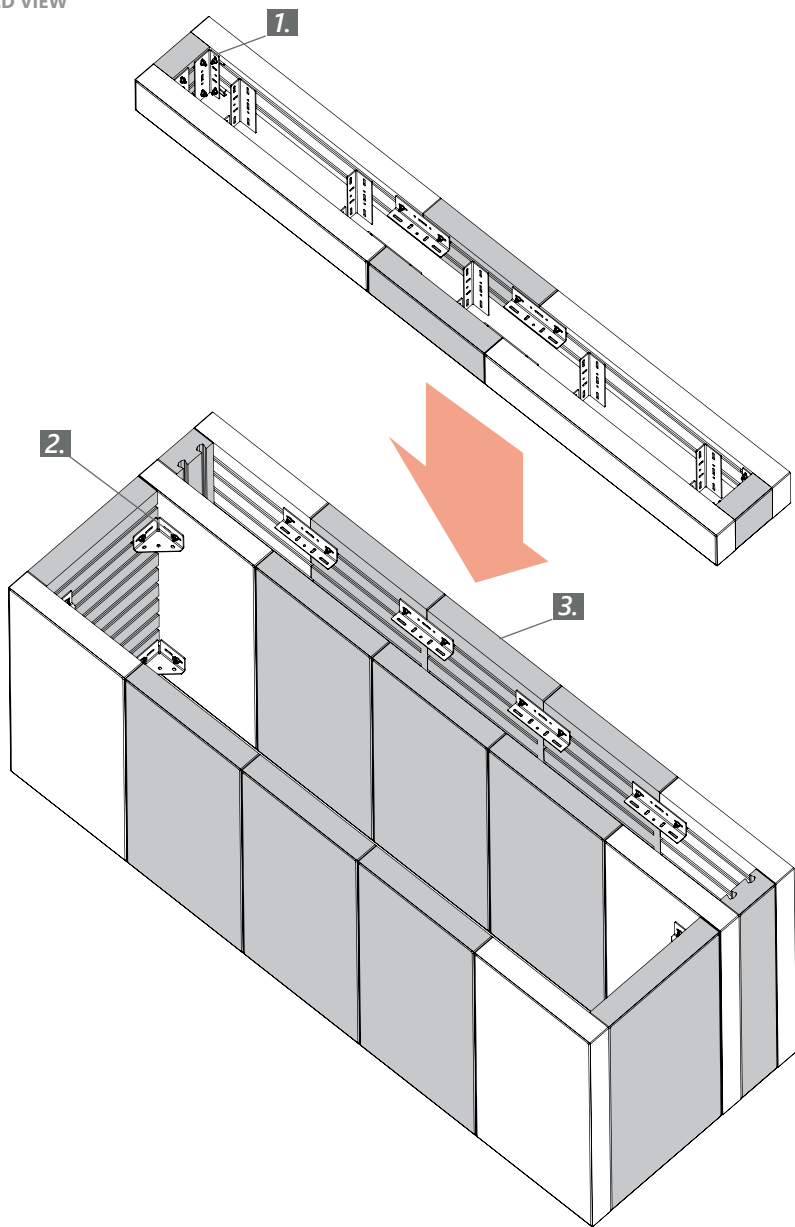

Use a JOINING PLATE for the top corners, to join the 4 panels.

Use an OUTER CORNER for the bottom corners.

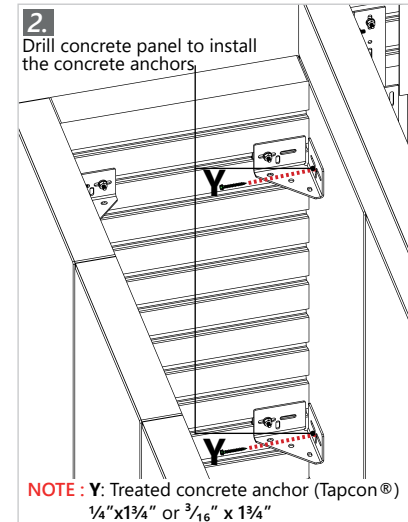

Drill concrete panel to install the concrete anchors.

**NOTE :** Y: Treated concrete anchor (Tapcon®) 1/4"x1 3/4" or 3/16" x 1 3/4"

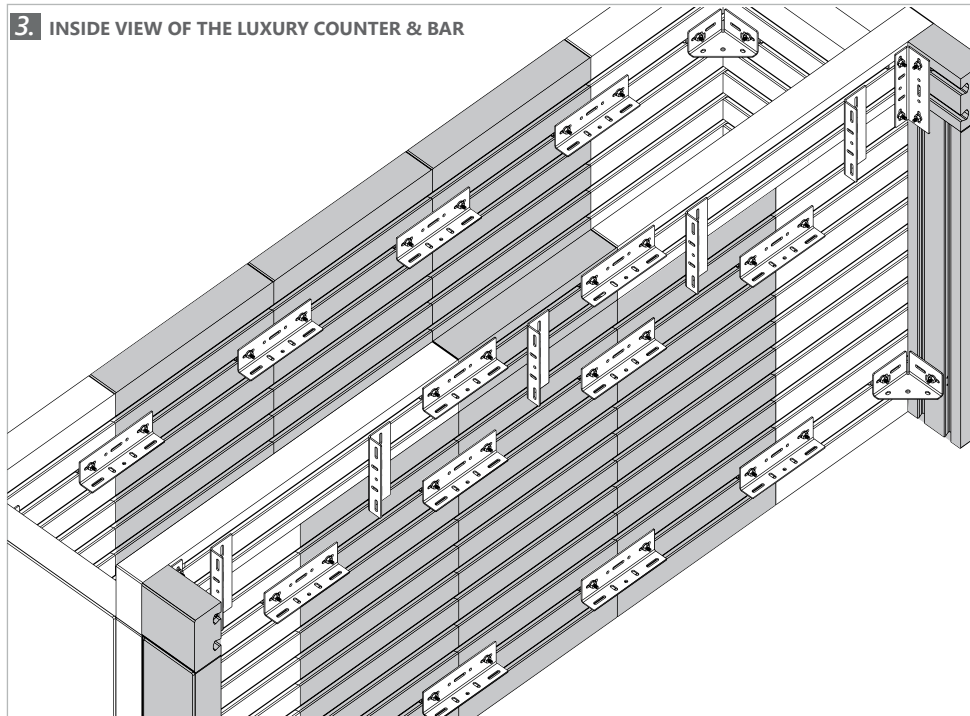



INTERIOR VIEW

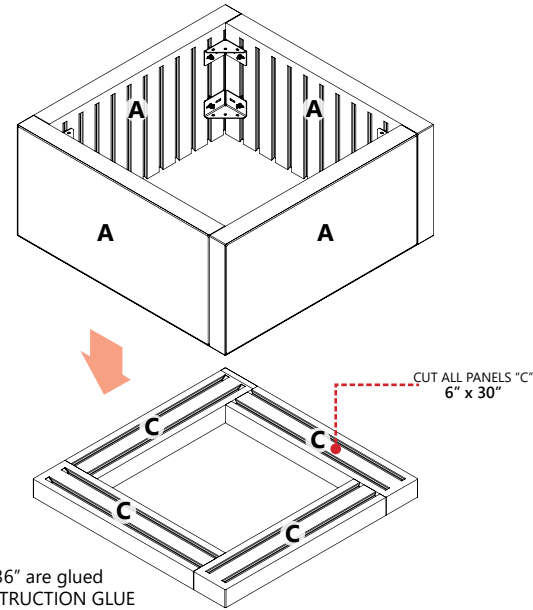

**NOTE:** The panels 18x36" are glued with 6x36" using CONSTRUCTION GLUE or STRUCTURE BOND

### REQUIRED PANELS

- 18" x 36" PANEL **4x**
- 18" x 36" PANEL **0x**
- 6" x 36" PANEL **4x**
- 6" x 36" PANEL **0x**

**IMPORTANT:** 18 x 36" panels are sold in pair/layer or in full pallet only. 6 x 36" panels are sold per unit or in layer or in full pallet.

FRONT VIEW

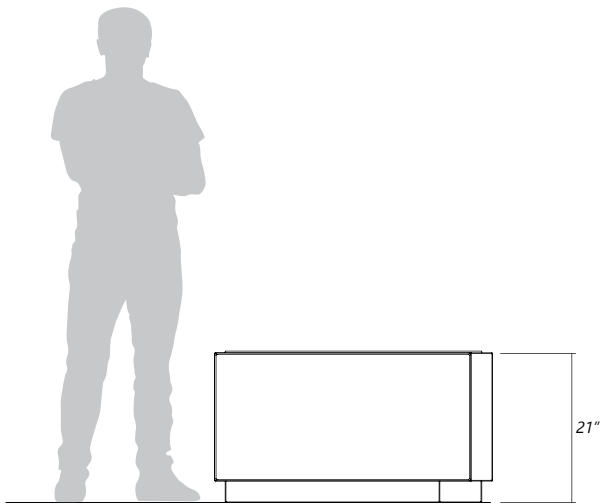

TOP VIEW

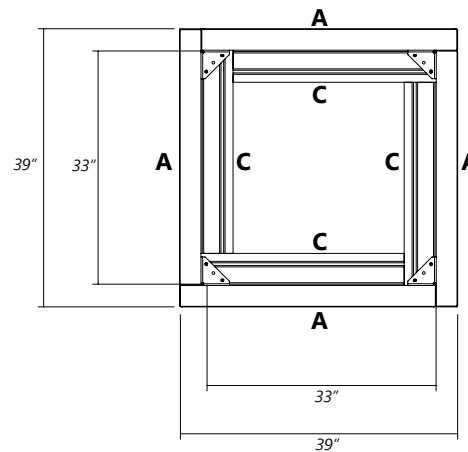

### REQUIRED HARDWARE

- ANCHOR SLIDE AND NUT **16x**  
**NOTE:** Sold only per box (100 units/box)
- JOINING PLATE **0x**  
**NOTE:** Can be sold per box or per unit (40 units/box)
- OUTER CORNER **8x**  
**NOTE:** Can be sold per box or per unit (48 units/box)
- INNER CORNER **0x**  
**NOTE:** Can be sold per box or per unit (24 units/box)
- STRETCHER **0x**  
**NOTE:** Can be sold per box or per unit (10 units/box)

**IMPORTANT:** It is recommended to follow the burner manufacturer's specifications for ventilation. Belgard is not responsible for the conformity of connections, clearances and ventilation. Metal liner plate and accessories are not included.

**TOTAL WEIGHT (PANELS & HARDWARE) 772 Lbs**



### INTERIOR VIEW

The 30"x30" burner pan is sitting directly on the ARTFORMS hardware, on the corner's brackets.

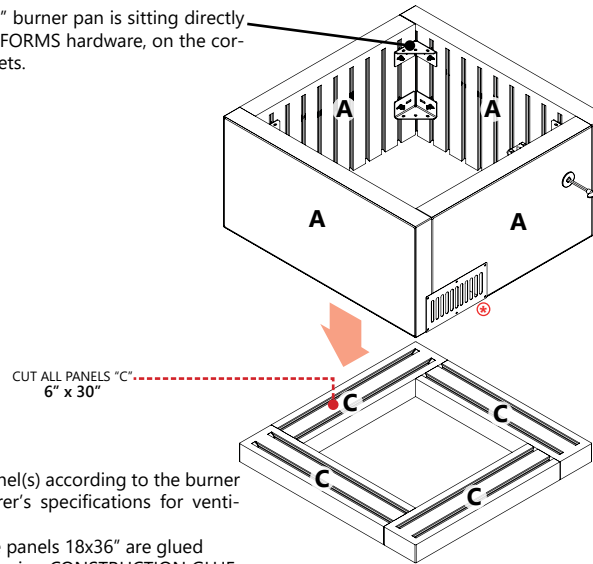

Ⓢ Cut panel(s) according to the burner manufacturer's specifications for ventilation.

**NOTE :** The panels 18x36" are glued with 6x36" using CONSTRUCTION GLUE or STRUCTURE BOND

### REQUIRED PANELS

- 18" x 36" PANEL **4x**
- 18" x 36" PANEL **0x**
- 6" x 36" PANEL **4x**
- 6" x 36" PANEL **0x**

**IMPORTANT:** 18 x 36" panels are sold in pair/layer or in full pallet only. 6 x 36" panels are sold per unit or in layer or in full pallet.

### FRONT VIEW

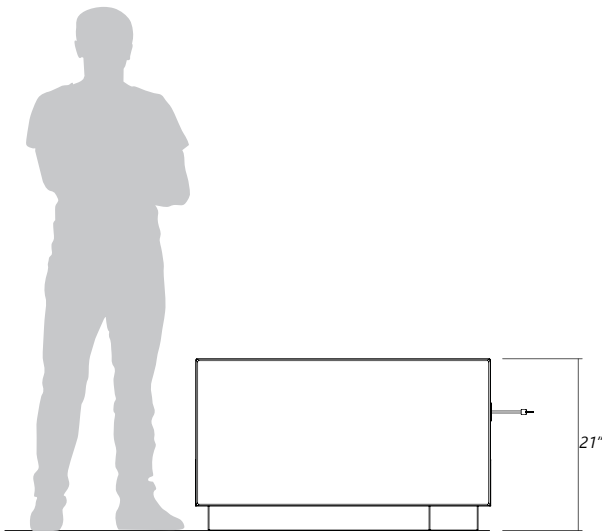

### TOP VIEW

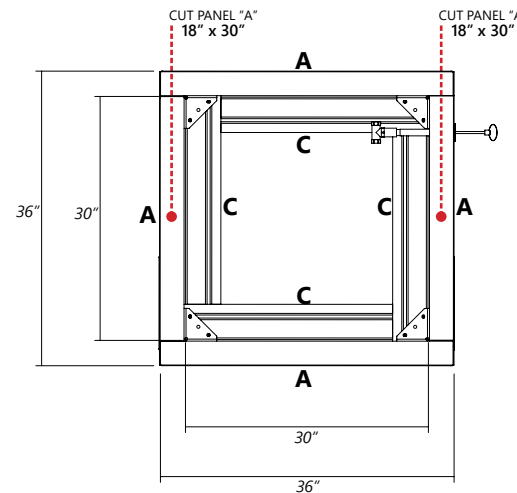

### REQUIRED HARDWARE

- ANCHOR SLIDE AND NUT **16x**  
**NOTE:** Sold only per box (100 units/box)
- JOINING PLATE **0x**  
**NOTE:** Can be sold per box or per unit (40 units/box)
- OUTER CORNER **8x**  
**NOTE:** Can be sold per box or per unit (48 units/box)
- INNER CORNER **0x**  
**NOTE:** Can be sold per box or per unit (24 units/box)
- STRETCHER **0x**  
**NOTE:** Can be sold per box or per unit (10 units/box)

**IMPORTANT:** It is recommended to follow the burner manufacturer's specifications for ventilation. Belgard is not responsible for the conformity of connections, clearances and ventilation. Burner pan and accessories are not included. PROPOSED MODEL: *Linzel SQUARE Burner 30" PLATE KIT*

**TOTAL WEIGHT (PANELS & HARDWARE) 683 Lbs**





**INTERIOR VIEW**

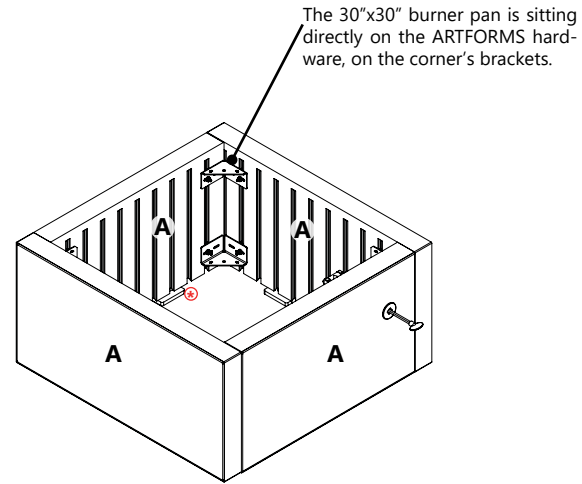

⊕ Add 0,5" thick PLASTIC SHIMS for ventilation

**REQUIRED PANELS**

- 18" x 36" PANEL** **4x**
- 18" x 36" PANEL** **0x**
- 6" x 36" PANEL** **0x**
- 6" x 36" PANEL** **0x**

**IMPORTANT:** 18 x 36" panels are sold in pair/layer or in full pallet only. 6 x 36" panels are sold per unit or in layer or in full pallet.

**FRONT VIEW**

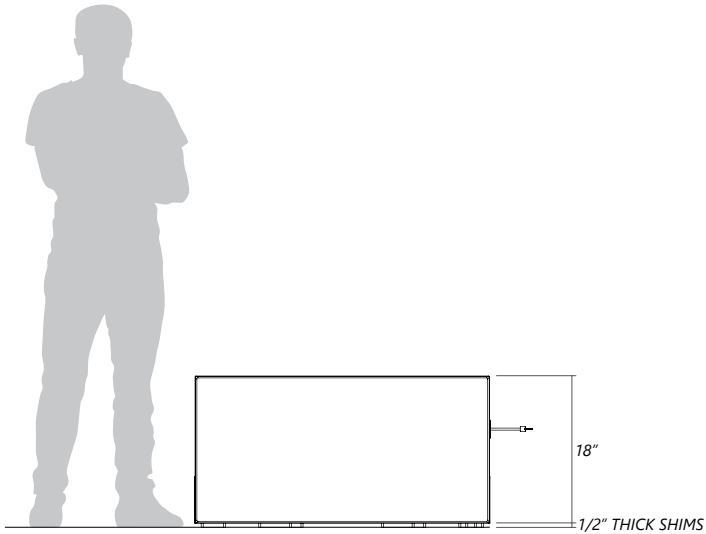

**TOP VIEW**

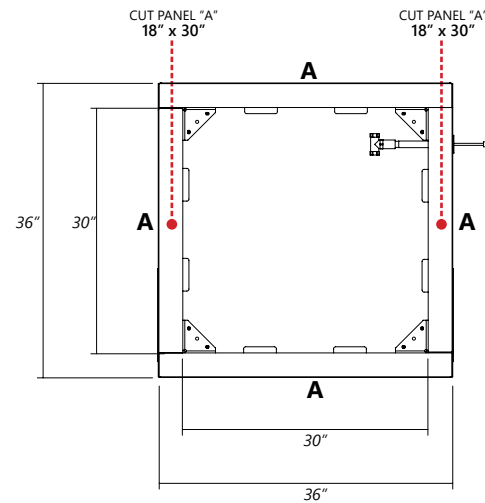

**REQUIRED HARDWARE**

- ANCHOR SLIDE AND NUT** **16x**  
*NOTE:* Sold only per box (100 units/box)
- JOINING PLATE** **0x**  
*NOTE:* Can be sold per box or per unit (40 units/box)
- OUTER CORNER** **8x**  
*NOTE:* Can be sold per box or per unit (48 units/box)
- INNER CORNER** **0x**  
*NOTE:* Can be sold per box or per unit (24 units/box)
- STRETCHER** **0x**  
*NOTE:* Can be sold per box or per unit (10 units/box)

**IMPORTANT:** It is recommended to follow the firekit manufacturer's specifications for ventilation. Belgard is not responsible for the conformity of connections, clearances and ventilation. Burner pan and accessories are not included. PROPOSED MODEL: Linzel SQUARE Burner 30" PLATE KIT

**TOTAL WEIGHT 535 Lbs**  
(PANELS & HARDWARE)

# RECESSED RECTANGULAR GAS FIRE PIT

ARTFORMS • PANEL SYSTEM



### INTERIOR VIEW

The panels on the top are glued using CONSTRUCTION GLUE or STRUCTURE BOND

The 17"x46" burner pan is sitting directly on the ARTFORMS hardware, on the joinings brackets.

⊕ Cut panel(s) according to the burner manufacturer's specifications for ventilation.

**NOTE:** The panels 18x36" are glued with 6x36" using CONSTRUCTION GLUE or STRUCTURE BOND

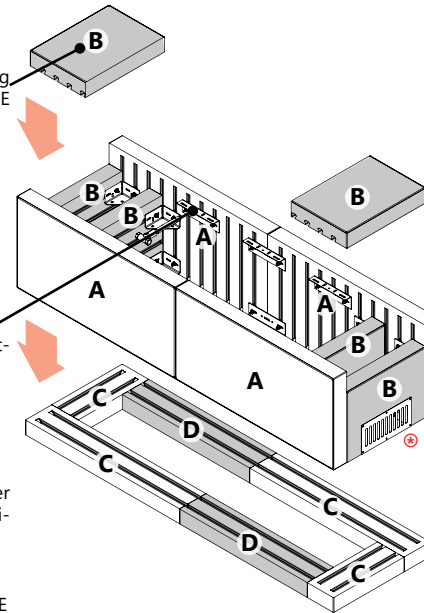

### REQUIRED PANELS

- 18" x 36" PANEL **4x**
- 18" x 36" PANEL **3x**
- 6" x 36" PANEL **4x**
- 6" x 36" PANEL **2x**

**IMPORTANT:** 18 x 36" panels are sold in pair/layer or in full pallet only. 6 x 36" panels are sold per unit or in layer or in full pallet.

### FRONT VIEW

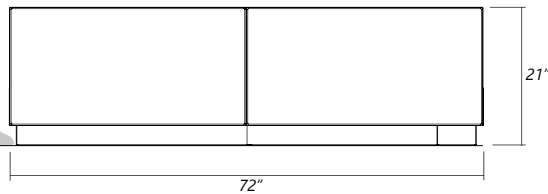

### TOP VIEW

#### WITHOUT TOP PANELS

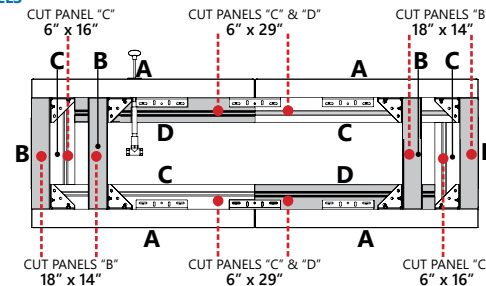

#### WITH TOP PANELS

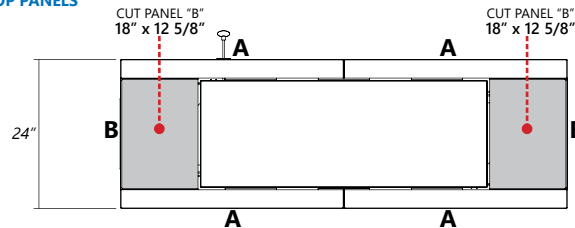

### REQUIRED HARDWARE

- ANCHOR SLIDE AND NUT **48x**  
**NOTE:** Sold only per box (100 units/box)
- JOINING PLATE **8x**  
**NOTE:** Can be sold per box or per unit (40 units/box)
- OUTER CORNER **16x**  
**NOTE:** Can be sold per box or per unit (48 units/box)
- INNER CORNER **0x**  
**NOTE:** Can be sold per box or per unit (24 units/box)
- STRETCHER **0x**  
**NOTE:** Can be sold per box or per unit (10 units/box)

**IMPORTANT:** It is recommended to follow the firekit manufacturer's specifications for ventilation. Belgard is not responsible for the conformity of connections, clearances and ventilation. Burner pan and accessories are not included. PROPOSED MODEL : Linzel H-STYLE Burner 46" x 17" PLATE KIT

**TOTAL WEIGHT 1130 Lbs**  
(PANELS & HARDWARE)



### INTERIOR VIEW

The panels on the top are glued using CONSTRUCTION GLUE or STRUCTURE BOND

The 17"x46" burner pan is sitting directly on the ARTFORMS hardware, on the joinings brackets.

- ⊕ Cut panel(s) according to the burner manufacturer's specifications for ventilation.
- ⊕ Add 0,5" thick PLASTIC SHIMS for ventilation

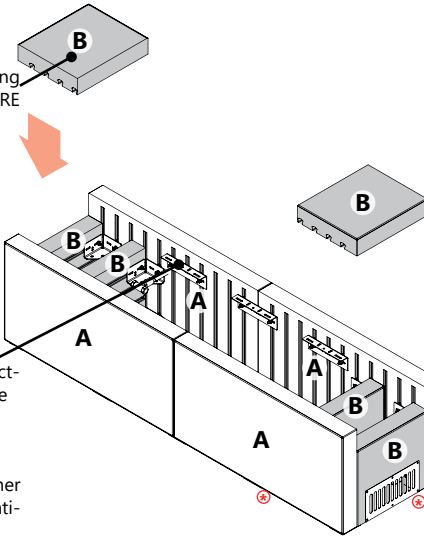

### FRONT VIEW

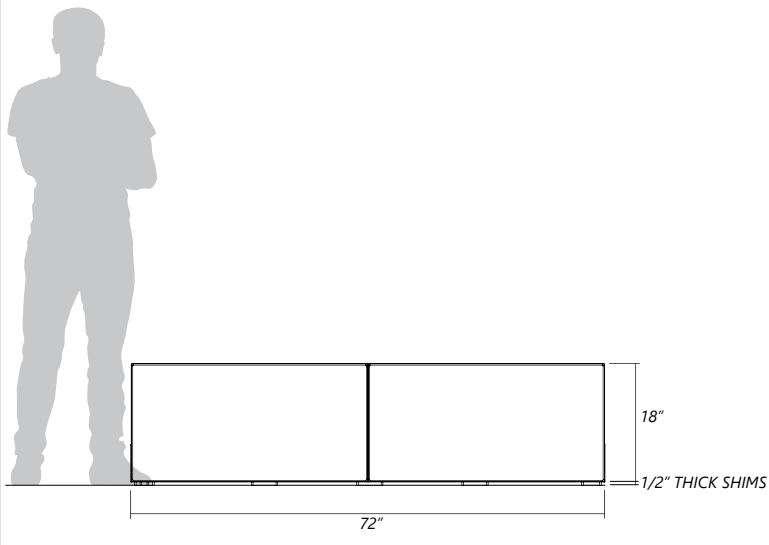

### TOP VIEW WITHOUT TOP LAYER

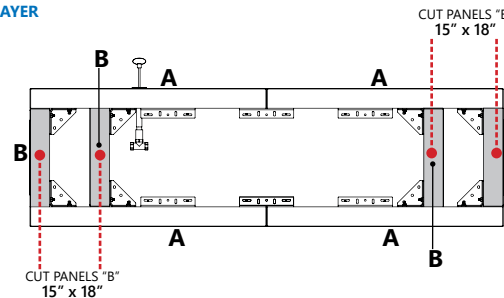

### WITH TOP LAYER

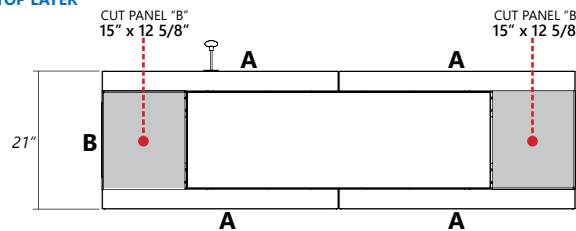

### REQUIRED PANELS

- CLOSED END  
 18" x 36" PANEL **4x**
- 18" x 36" PANEL **3x**
- CLOSED END  
 6" x 36" PANEL **0x**
- 6" x 36" PANEL **0x**

**IMPORTANT:** 18 x 36" panels are sold in pair/layer or in full pallet only. 6 x 36" panels are sold per unit or in layer or in full pallet.

### REQUIRED HARDWARE

- ANCHOR SLIDE AND NUT **48x**  
NOTE: Sold only per box (100 units/box)
- JOINING PLATE **8x**  
NOTE: Can be sold per box or per unit (40 units/box)
- OUTER CORNER **16x**  
NOTE: Can be sold per box or per unit (48 units/box)
- INNER CORNER **0x**  
NOTE: Can be sold per box or per unit (24 units/box)
- STRETCHER **0x**  
NOTE: Can be sold per box or per unit (10 units/box)

**IMPORTANT:** It is recommended to follow the firekit manufacturer's specifications for ventilation. Belgard is not responsible for the conformity of connections, clearances and ventilation. Burner plate and accessories are not included. PROPOSED MODEL : Linzel H-STYLE Burner 46" x 15" PLATE KIT

**TOTAL WEIGHT (PANELS & HARDWARE) 880 Lbs**



INTERIOR VIEW

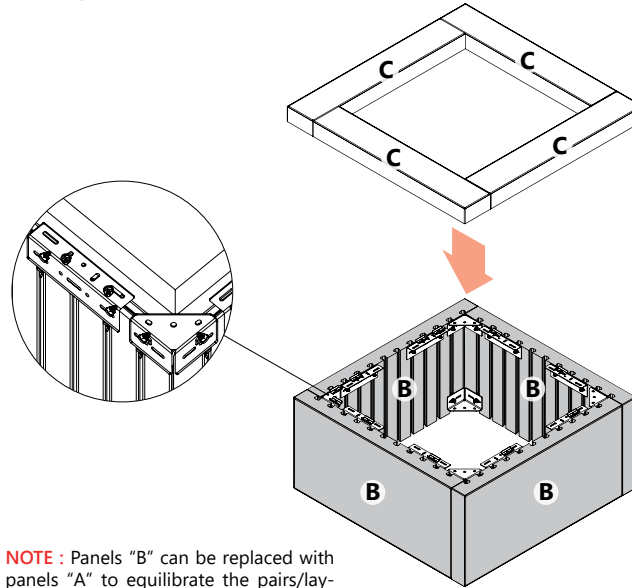

**NOTE :** Panels "B" can be replaced with panels "A" to equilibrate the pairs/layers. Panels "A" can't be replaced by the panels "B".

**REQUIRED PANELS**

- 18" x 36" PANEL **0x**
- 18" x 36" PANEL **4x**
- 6" x 36" PANEL **4x**
- 6" x 36" PANEL **0x**

**IMPORTANT:** 18 x 36" panels are sold in pair/layer or in full pallet only. 6 x 36" panels are sold per unit or in layer or in full pallet.

FRONT VIEW

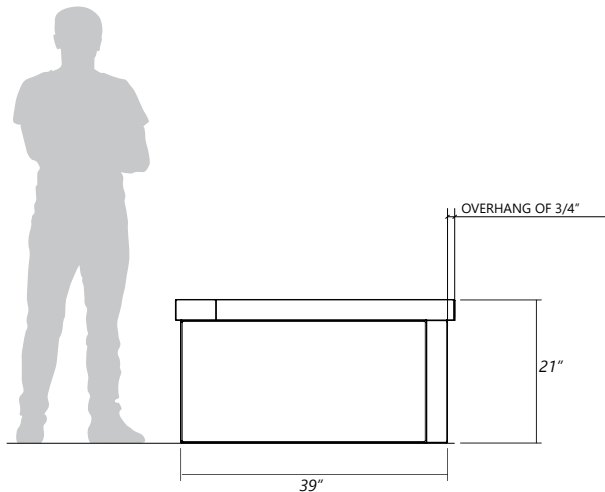

TOP VIEW

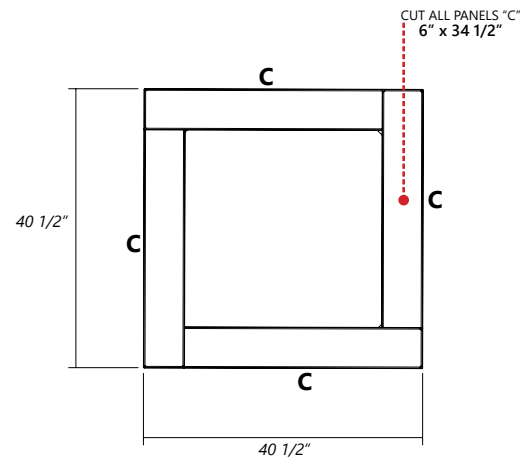

**REQUIRED HARDWARE**

- ANCHOR SLIDE AND NUT **40x**  
**NOTE:** Sold only per box (100 units/box)
- JOINING PLATE **8x**  
**NOTE:** Can be sold per box or per unit (40 units/box)
- OUTER CORNER **8x**  
**NOTE:** Can be sold per box or per unit (48 units/box)
- INNER CORNER **0x**  
**NOTE:** Can be sold per box or per unit (24 units/box)
- STRETCHER **0x**  
**NOTE:** Can be sold per box or per unit (10 units/box)

**IMPORTANT:** Refer to page 23 of the ARTFORMS INSTALLATION GUIDE about the installation of geotextile in planter box. Contact experts/engineers to validate the base preparation, the drainage, the plants & roots growth/management.

**TOTAL WEIGHT (PANELS & HARDWARE) 804 Lbs**



# 19. RECTANGULAR PLANTER

ARTFORMS • PANEL SYSTEM



INTERIOR VIEW

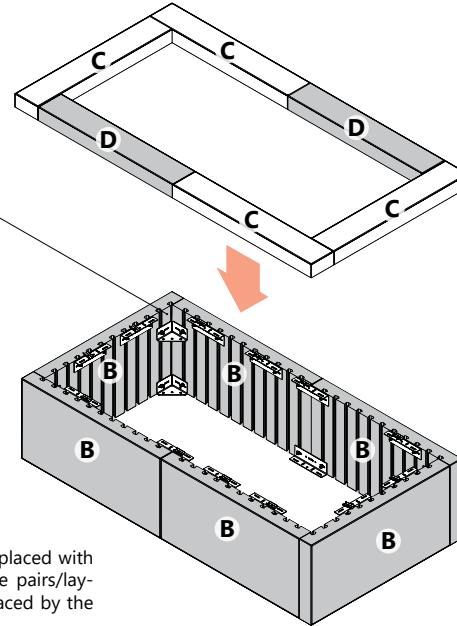
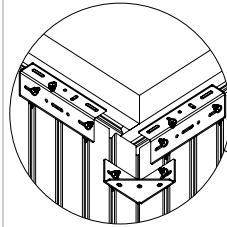

**NOTE :** Panels "B" can be replaced with panels "A" to equilibrate the pairs/layers. Panels "A" can't be replaced by the panels "B".

## REQUIRED PANELS

	18" x 36" PANEL	<b>0x</b>
	18" x 36" PANEL	<b>6x</b>
	6" x 36" PANEL	<b>4x</b>
	6" x 36" PANEL	<b>2x</b>

**IMPORTANT:** 18 x 36" panels are sold in pair/layer or in full pallet only. 6 x 36" panels are sold per unit or in layer or in full pallet.

FRONT VIEW

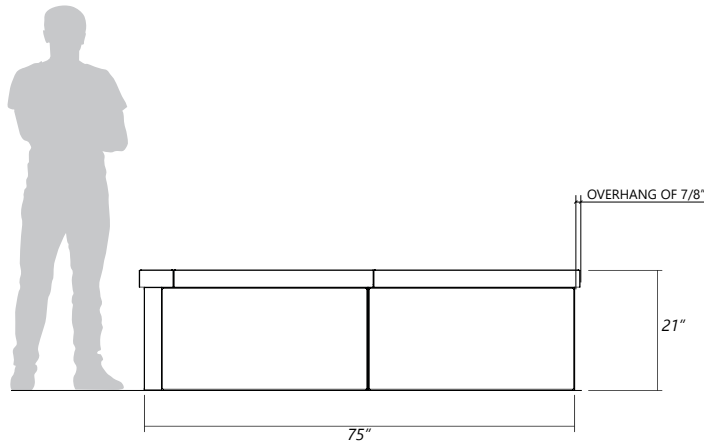

TOP VIEW

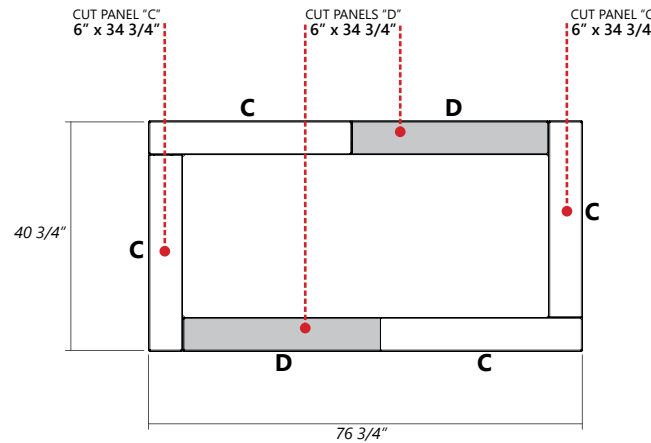

## REQUIRED HARDWARE

	<b>ANCHOR SLIDE AND NUT</b> <b>56x</b> <small>NOTE: Sold only per box (100 units/box)</small>
	<b>JOINING PLATE</b> <b>14x</b> <small>NOTE: Can be sold per box or per unit (40 units/box)</small>
	<b>OUTER CORNER</b> <b>8x</b> <small>NOTE: Can be sold per box or per unit (48 units/box)</small>
	<b>INNER CORNER</b> <b>0x</b> <small>NOTE: Can be sold per box or per unit (24 units/box)</small>
	<b>STRETCHER</b> <b>0x</b> <small>NOTE: Can be sold per box or per unit (10 units/box)</small>

**IMPORTANT:** Refer to page 23 of the ARTFORMS INSTALLATION GUIDE about the installation of geotextile in planter box. Contact experts/engineers to validate the base preparation, the drainage, the plants & roots growth/management.

**TOTAL WEIGHT 1209 Lbs**  
(PANELS & HARDWARE)

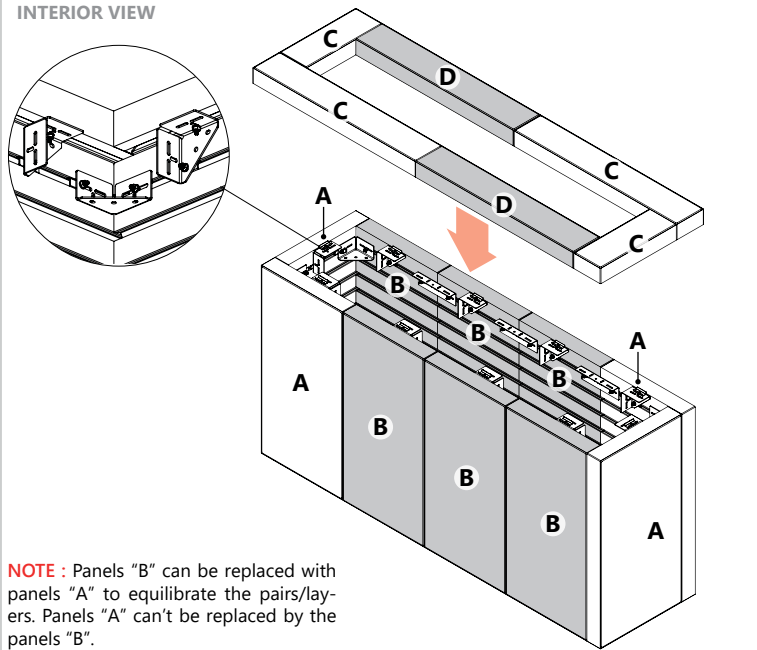

**REQUIRED PANELS**

	18" x 36" PANEL	<b>4x</b>
	18" x 36" PANEL	<b>6x</b>
	6" x 36" PANEL	<b>4x</b>
	6" x 36" PANEL	<b>2x</b>

**IMPORTANT:** 18 x 36" panels are sold in pair/layer or in full pallet only. 6 x 36" panels are sold per unit or in layer or in full pallet.

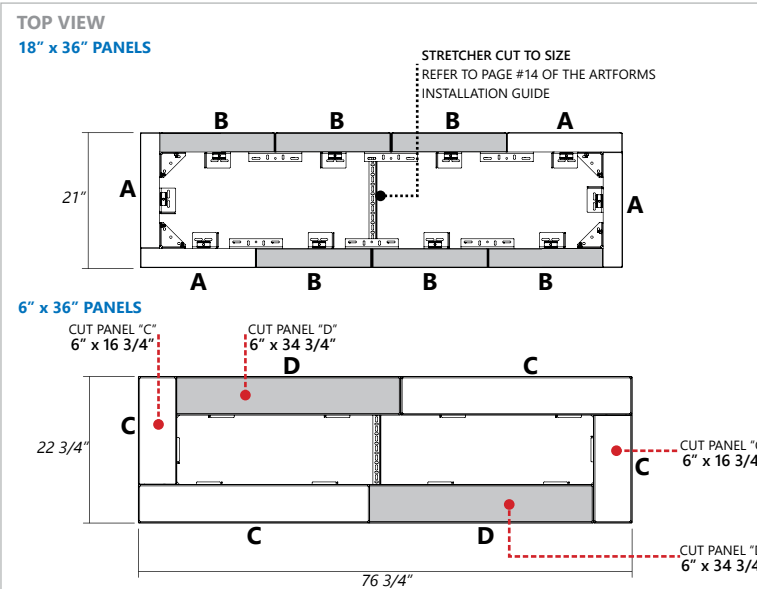
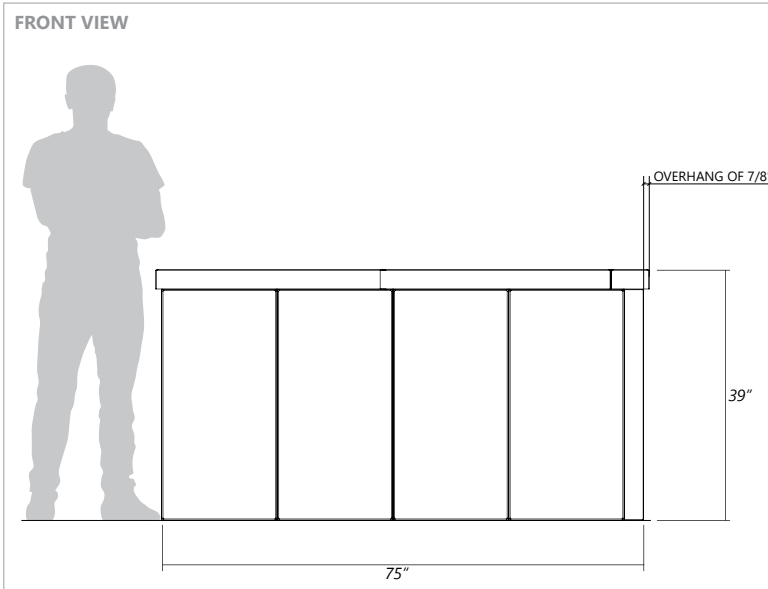

**REQUIRED HARDWARE**

	<b>ANCHOR SLIDE AND NUT</b> <b>62x</b> <small>NOTE: Sold only per box (100 units/box)</small>
	<b>JOINING PLATE</b> <b>12x</b> <small>NOTE: Can be sold per box or per unit (40 units/box)</small>
	<b>OUTER CORNER</b> <b>18x</b> <small>NOTE: Can be sold per box or per unit (48 units/box)</small>
	<b>INNER CORNER</b> <b>0x</b> <small>NOTE: Can be sold per box or per unit (24 units/box)</small>
	<b>STRETCHER</b> <b>1x</b> <small>NOTE: Can be sold per box or per unit (10 units/box)</small>

**IMPORTANT:** Refer to page 23 of the ARTFORMS INSTALLATION GUIDE about the installation of geotextile in planter box. Contact experts/engineers to validate the base preparation, the drainage, the plants & roots growth/management.

**TOTAL WEIGHT 1765 Lbs**  
(PANELS & HARDWARE)



### INTERIOR VIEW

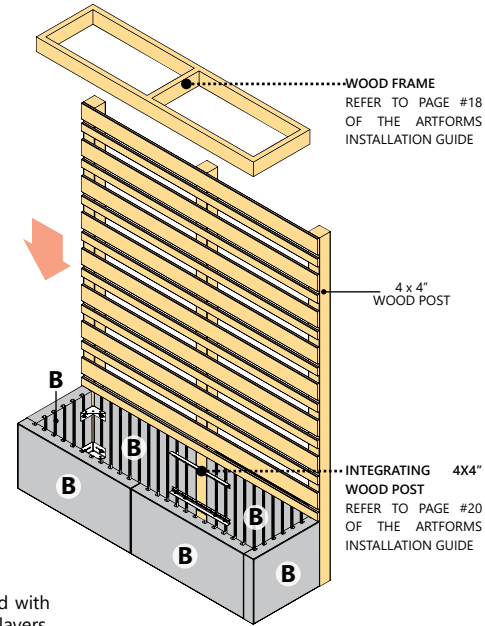
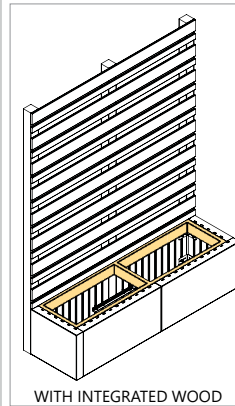

**NOTE :** Panels "B" can be replaced with panels "A" to equilibrate the pairs/layers.

### REQUIRED PANELS

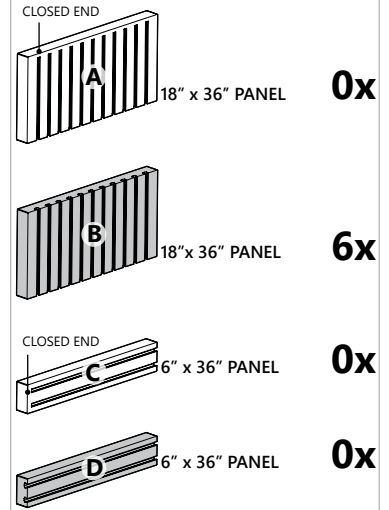

**IMPORTANT:** 18 x 36" panels are sold in pair/layer or in full pallet only. 6 x 36" panels are sold per unit or in layer or in full pallet.

### FRONT VIEW

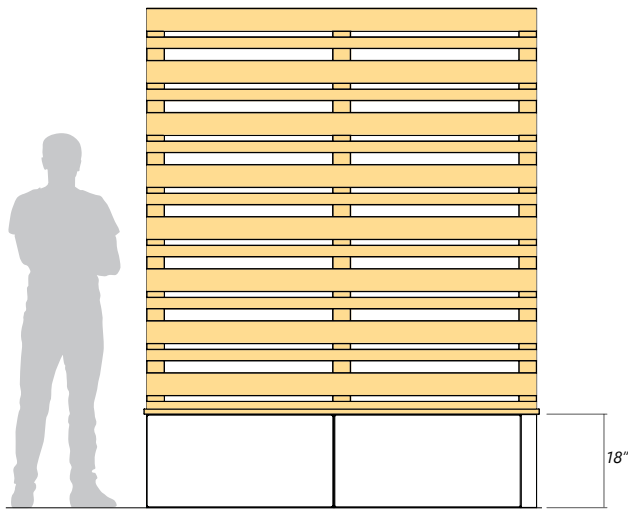

### TOP VIEW

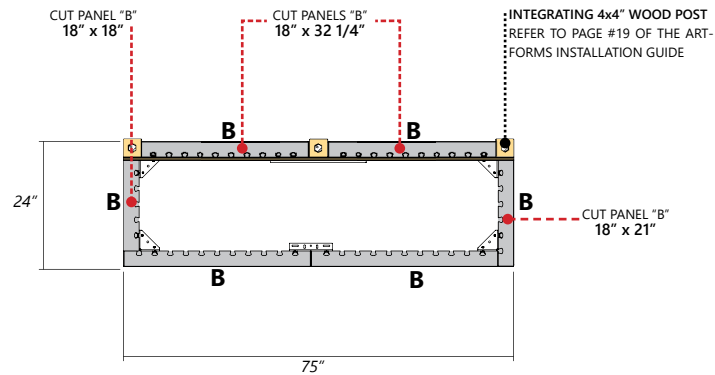

### REQUIRED HARDWARE

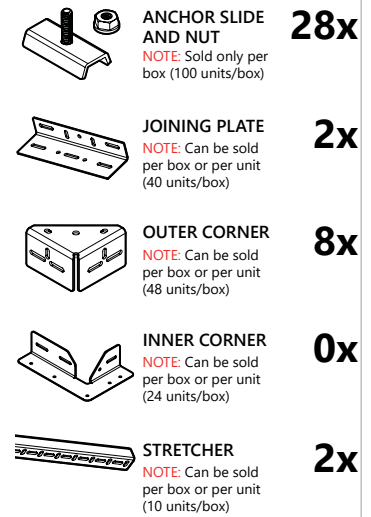

**TOTAL WEIGHT 740 Lbs**  
(PANELS & HARDWARE)



### INTERIOR VIEW

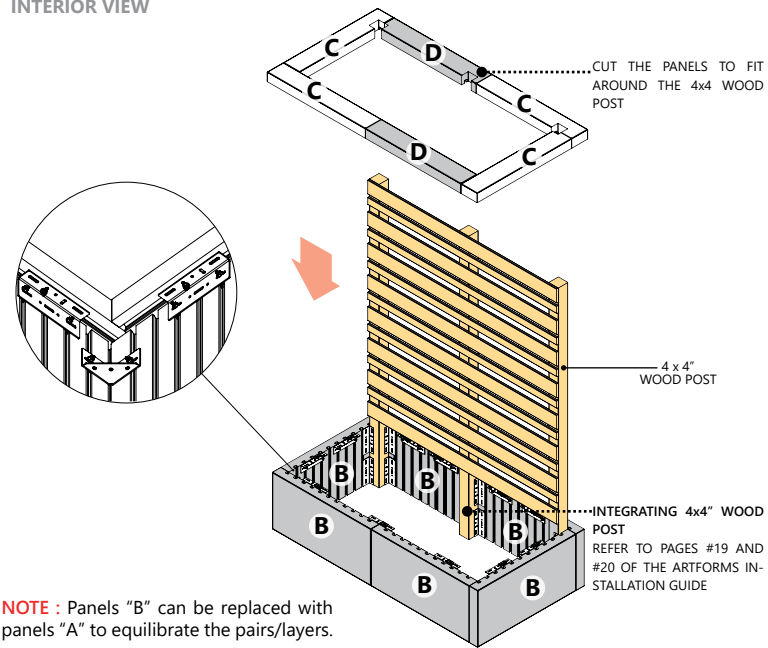

### FRONT VIEW

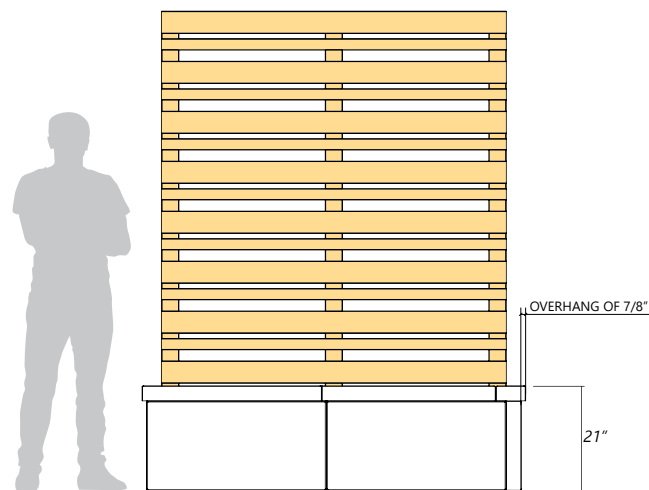

### TOP VIEW

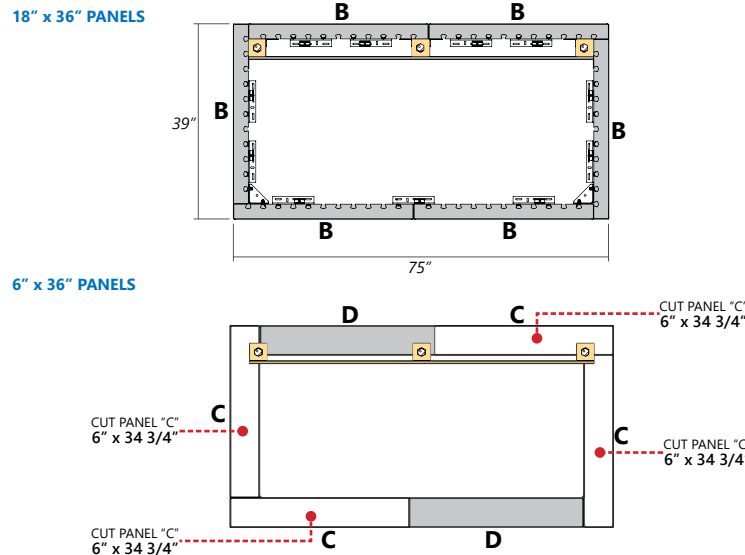

### REQUIRED PANELS

- CLOSED END 18" x 36" PANEL **0x**
- 18" x 36" PANEL **6x**
- CLOSED END 6" x 36" PANEL **4x**
- 6" x 36" PANEL **2x**

**IMPORTANT:** 18 x 36" panels are sold in pair/layer or in full pallet only. 6 x 36" panels are sold per unit or in layer or in full pallet.

### REQUIRED HARDWARE

- ANCHOR SLIDE AND NUT **43x**  
*NOTE:* Sold only per box (100 units/box)
- JOINING PLATE **24x**  
*NOTE:* Can be sold per box or per unit (40 units/box)
- OUTER CORNER **4x**  
*NOTE:* Can be sold per box or per unit (48 units/box)
- INNER CORNER **0x**  
*NOTE:* Can be sold per box or per unit (24 units/box)
- STRETCHER **0x**  
*NOTE:* Can be sold per box or per unit (10 units/box)

**IMPORTANT:** Refer to page 23 of the ARTFORMS INSTALLATION GUIDE about the installation of geotextile in planter box. Contact experts/engineers to validate the base preparation, the drainage, the plants & roots growth/management.

**TOTAL WEIGHT 1206 Lbs**  
(PANELS & HARDWARE)



# 23. PRIVACY WALL WITH VERTICAL PLANTER

ARTFORMS • PANEL SYSTEM



## INTERIOR VIEW

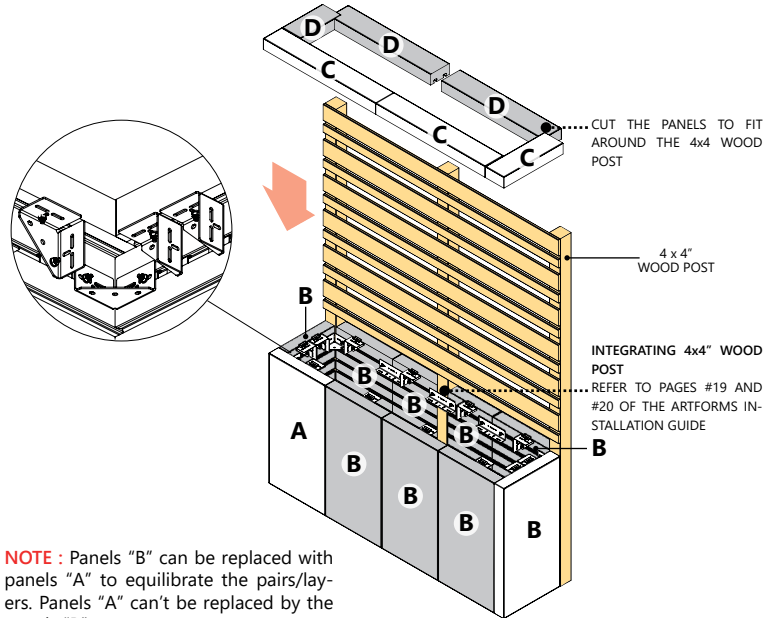

**NOTE :** Panels "B" can be replaced with panels "A" to equilibrate the pairs/layers. Panels "A" can't be replaced by the panels "B".

## REQUIRED PANELS

- CLOSED END  
 18" x 36" PANEL **2x**
- 18" x 36" PANEL **8x**
- CLOSED END  
 6" x 36" PANEL **3x**
- 6" x 36" PANEL **3x**

**IMPORTANT:** 18 x 36" panels are sold in pair/layer or in full pallet only. 6 x 36" panels are sold per unit or in layer or in full pallet.

## FRONT VIEW

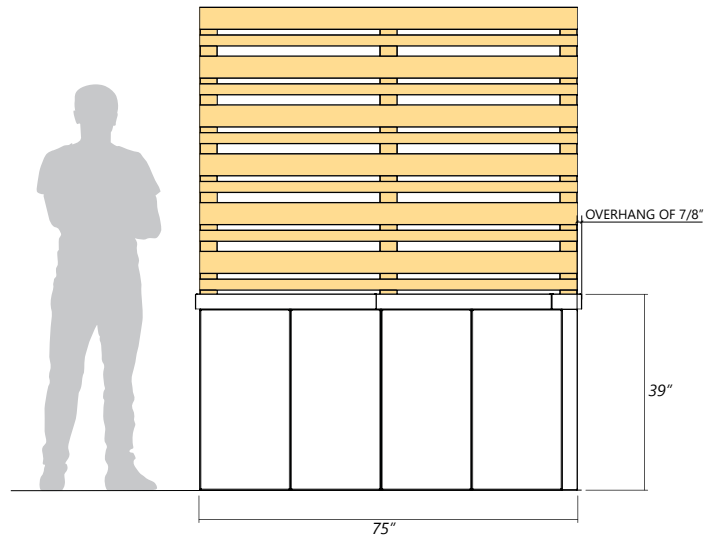

## TOP VIEW

### 18" x 36" PANELS

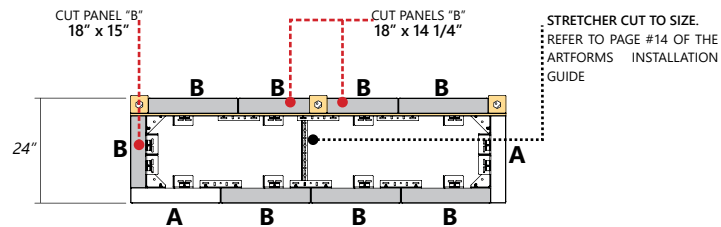

### 6" x 36" PANELS

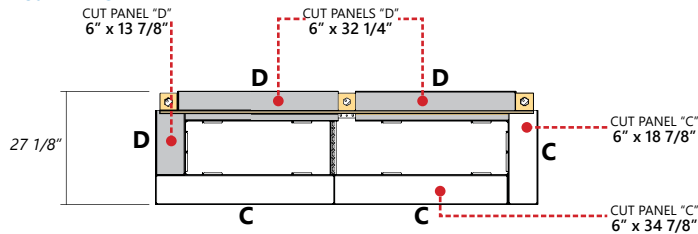

## REQUIRED HARDWARE

- ANCHOR SLIDE AND NUT **66x**  
**NOTE:** Sold only per box (100 units/box)
- JOINING PLATE **12x**  
**NOTE:** Can be sold per box or per unit (40 units/box)
- OUTER CORNER **20x**  
**NOTE:** Can be sold per box or per unit (48 units/box)
- INNER CORNER **0x**  
**NOTE:** Can be sold per box or per unit (24 units/box)
- STRETCHER **1x**  
**NOTE:** Can be sold per box or per unit (10 units/box)

**IMPORTANT:** Refer to page 23 of the ARTFORMS INSTALLATION GUIDE about the installation of geotextile in planter box. Contact experts/engineers to validate the base preparation, the drainage, the plants & roots growth/management.

**TOTAL WEIGHT 1667 Lbs**  
(PANELS & HARDWARE)



### INTERIOR VIEW

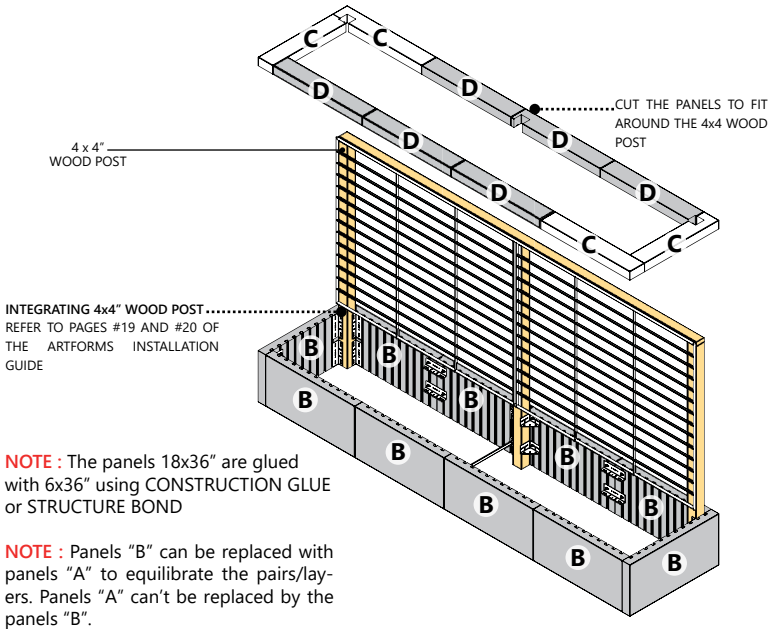

### REQUIRED PANELS

- CLOSED END  
18" x 36" PANEL **0x**
- 18" x 36" PANEL **10x**
- CLOSED END  
6" x 36" PANEL **4x**
- 6" x 36" PANEL **6x**

**IMPORTANT:** 18 x 36" panels are sold in pair/layer or in full pallet only. 6 x 36" panels are sold per unit or in layer or in full pallet.

### FRONT VIEW

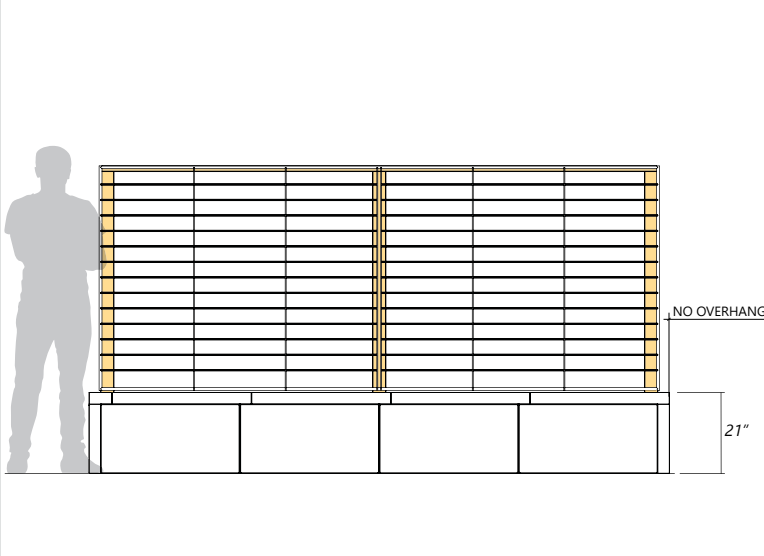

### TOP VIEW

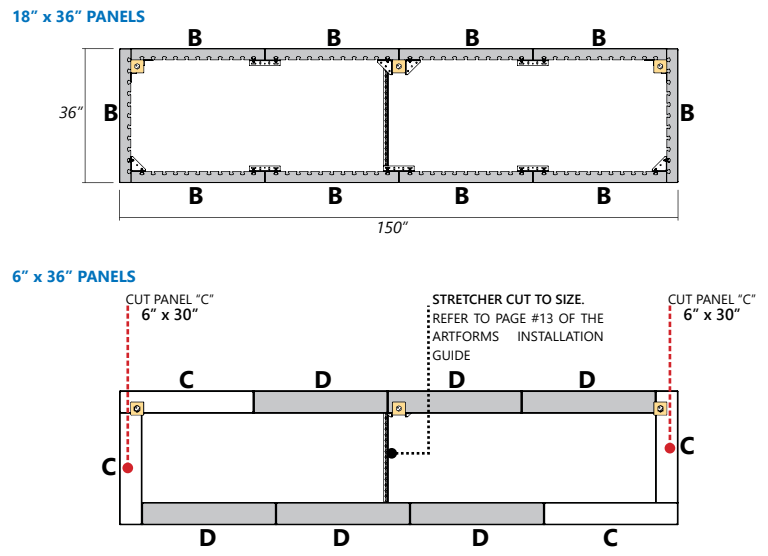

### REQUIRED HARDWARE

- ANCHOR SLIDE AND NUT **54x**  
**NOTE:** Sold only per box (100 units/box)
- JOINING PLATE **18x**  
**NOTE:** Can be sold per box or per unit (40 units/box)
- OUTER CORNER **8x**  
**NOTE:** Can be sold per box or per unit (48 units/box)
- INNER CORNER **0x**  
**NOTE:** Can be sold per box or per unit (24 units/box)
- STRETCHER **1x**  
**NOTE:** Can be sold per box or per unit (10 units/box)

**IMPORTANT:** Refer to page 23 of the ARTFORMS INSTALLATION GUIDE about the installation of geotextile in planter box. Contact experts/engineers to validate the base preparation, the drainage, the plants & roots growth/management.

**TOTAL WEIGHT 1986 Lbs**  
(PANELS & HARDWARE)



INTERIOR VIEW

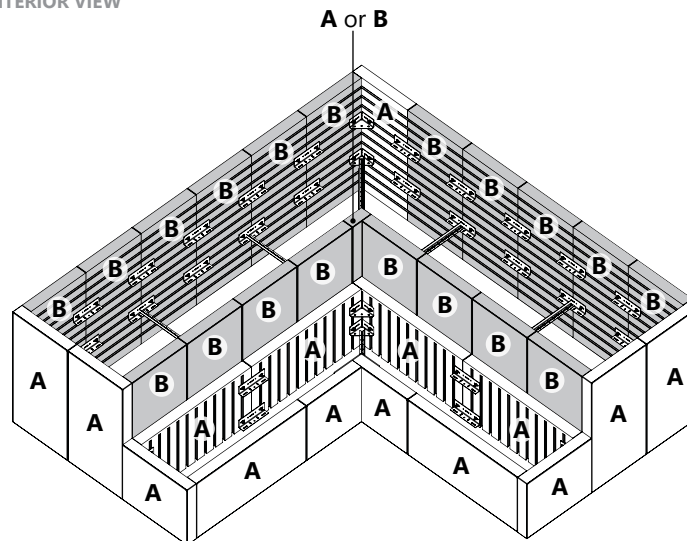

**NOTE :** Panels "B" can be replaced with panels "A" to equilibrate the pairs/layers. Panels "A" can't be replaced by the panels "B".

**REQUIRED PANELS**

- 15x**  
18" x 36" PANEL
- 20x**  
18" x 36" PANEL
- 0x**  
6" x 36" PANEL
- 0x**  
6" x 36" PANEL

**IMPORTANT:** 18 x 36" panels are sold in pair/layer or in full pallet only. 6 x 36" panels are sold per unit or in layer or in full pallet.

FRONT VIEW

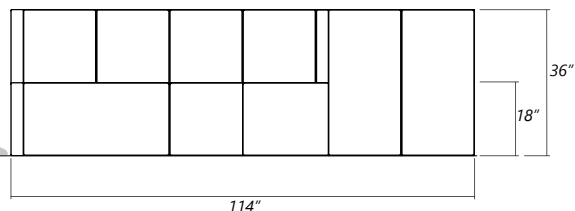

TOP VIEW

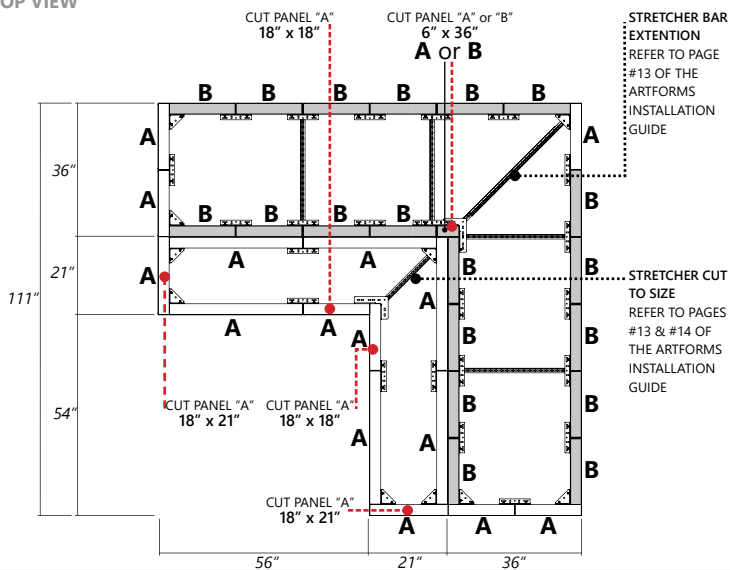

**REQUIRED HARDWARE**

- 153x**  
ANCHOR SLIDE AND NUT  
**NOTE:** Sold only per box (100 units/box)
- 46x**  
JOINING PLATE  
**NOTE:** Can be sold per box or per unit (40 units/box)
- 20x**  
OUTER CORNER  
**NOTE:** Can be sold per box or per unit (48 units/box)
- 4x**  
INNER CORNER  
**NOTE:** Can be sold per box or per unit (24 units/box)
- 7x**  
STRETCHER  
**NOTE:** Can be sold per box or per unit (10 units/box)

**IMPORTANT:** Refer to page 23 of the ARTFORMS INSTALLATION GUIDE about the installation of geotextile in planter box. Contact experts/engineers to validate the base preparation, the drainage, the plants & roots growth/management.

**TOTAL WEIGHT (PANELS & HARDWARE) 4937 Lbs**

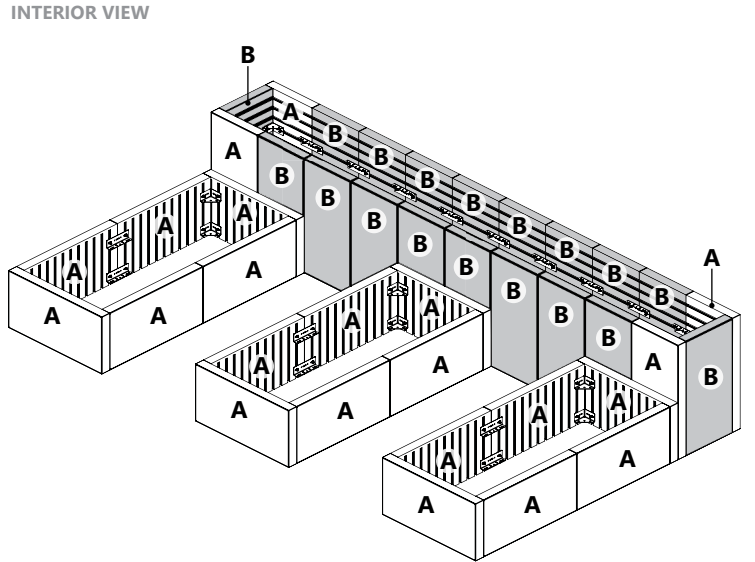

**NOTE :** Panels "B" can be replaced with panels "A" to equilibrate the pairs/layers. Panels "A" can't be replaced by the panels "B".

**REQUIRED PANELS**

- 22x**  
CLOSED END  
18" x 36" PANEL
- 18x**  
18" x 36" PANEL
- 0x**  
CLOSED END  
6" x 36" PANEL
- 0x**  
6" x 36" PANEL

**IMPORTANT:** 18 x 36" panels are sold in pair/layer or in full pallet only. 6 x 36" panels are sold per unit or in layer or in full pallet.

**FRONT VIEW**

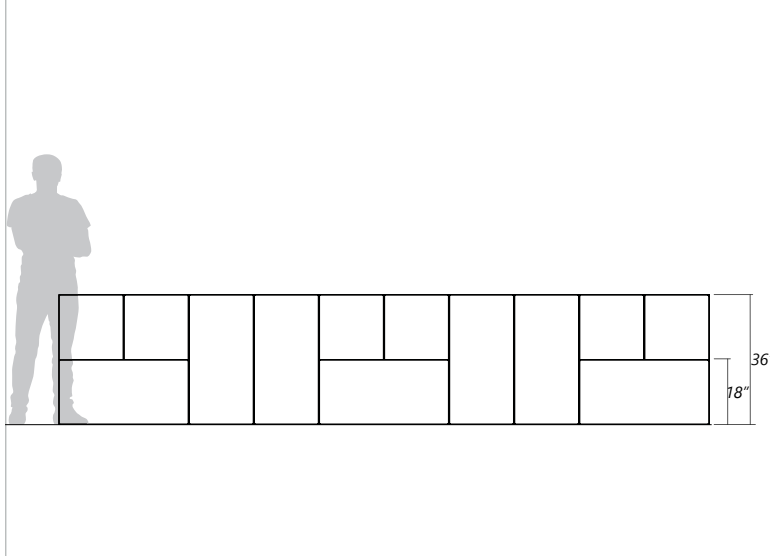

**TOP VIEW**

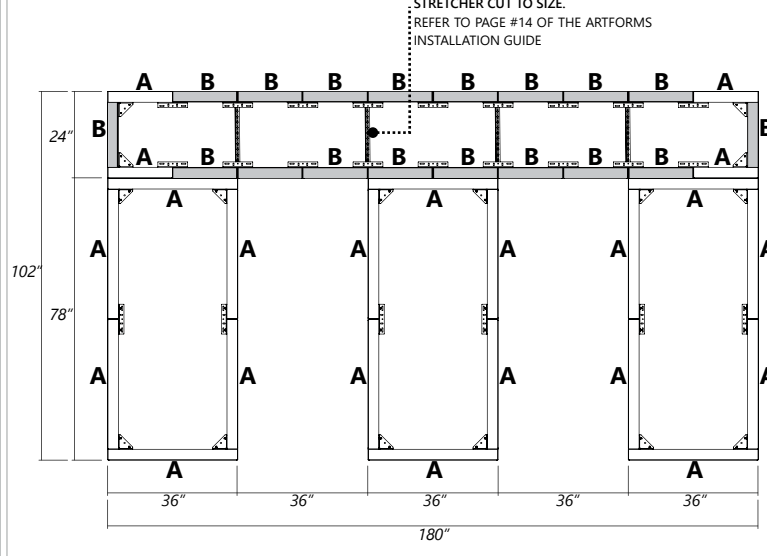

**REQUIRED HARDWARE**

- 168x**  
ANCHOR SLIDE AND NUT  
**NOTE:** Sold only per box (100 units/box)
- 48x**  
JOINING PLATE  
**NOTE:** Can be sold per box or per unit (40 units/box)
- 32x**  
OUTER CORNER  
**NOTE:** Can be sold per box or per unit (48 units/box)
- 0x**  
INNER CORNER  
**NOTE:** Can be sold per box or per unit (24 units/box)
- 2x**  
STRETCHER  
**NOTE:** Can be sold per box or per unit (10 units/box)

**IMPORTANT:** Refer to page 23 of the ARTFORMS INSTALLATION GUIDE about the installation of geotextile in planter box. Contact experts/engineers to validate the base preparation, the drainage, the plants & roots growth/management.

**TOTAL WEIGHT 6058 Lbs**  
(PANELS & HARDWARE)



# FIREPLACE WITH BENCH & WOOD PERGOLA

ARTFORMS • PANEL SYSTEM

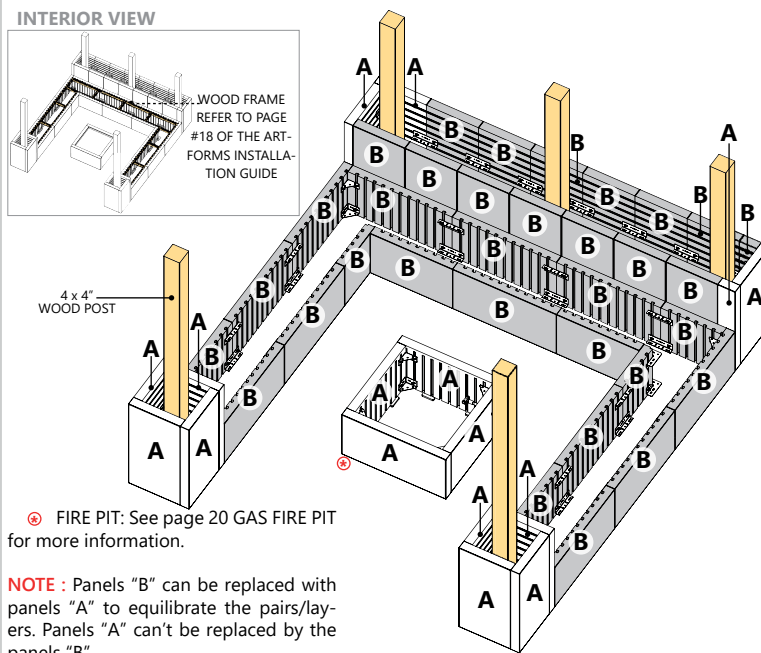

**REQUIRED PANELS**

- CLOSED END  
 18" x 36" PANEL **16x**
- 18" x 36" PANEL **34x**
- CLOSED END  
 6" x 36" PANEL **0x**
- 6" x 36" PANEL **0x**

**IMPORTANT:** 18 x 36" panels are sold in pair/layer or in full pallet only. 6 x 36" panels are sold per unit or in layer or in full pallet.

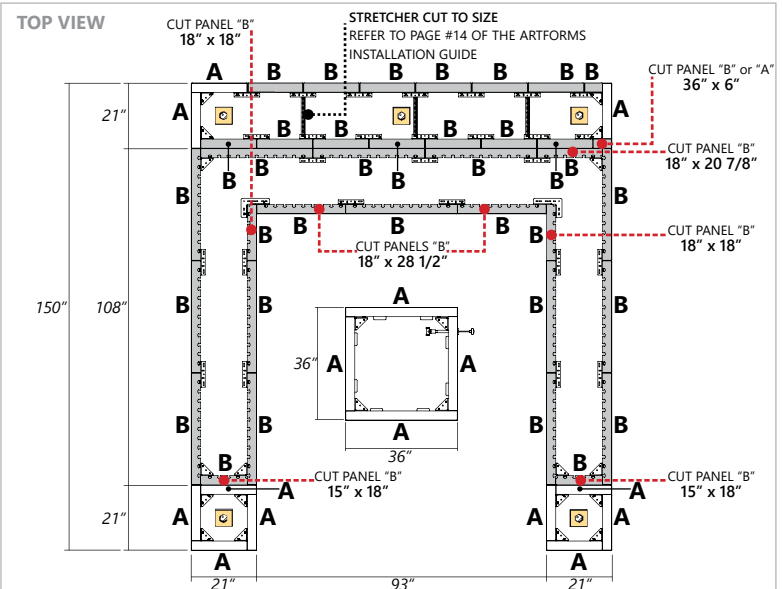
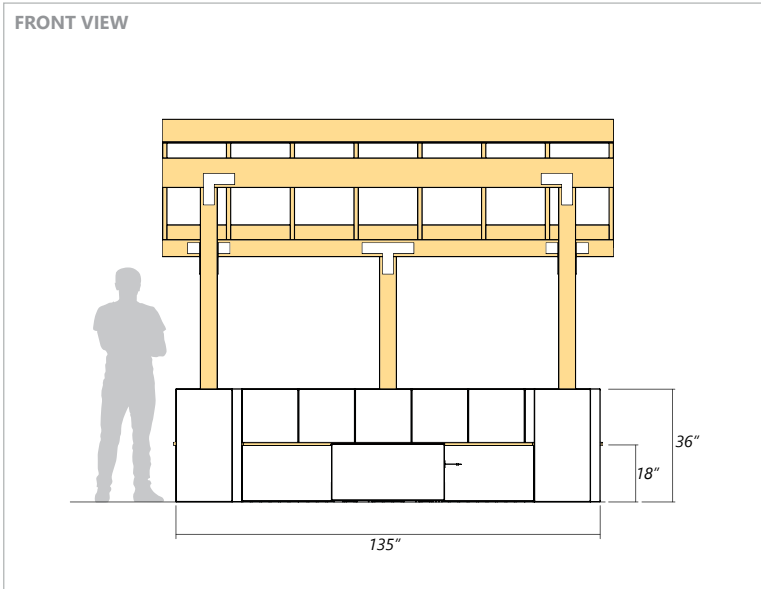

**REQUIRED HARDWARE**

- ANCHOR SLIDE AND NUT** **210x**  
NOTE: Sold only per box (100 units/box)
- JOINING PLATE** **54x**  
NOTE: Can be sold per box or per unit (40 units/box)
- OUTER CORNER** **44x**  
NOTE: Can be sold per box or per unit (48 units/box)
- INNER CORNER** **4x**  
NOTE: Can be sold per box or per unit (24 units/box)
- STRETCHER** **2x**  
NOTE: Can be sold per box or per unit (10 units/box)

**IMPORTANT:** Other types of hardware (not included) may be required to make these assemblies (wood screws, concrete anchors, etc.). BELGARD is not responsible for any issue regarding other materials, accessories, other types of hardware, etc. We recommend to consulting an expert/engineer to validate installation of the wood posts of pergola.

**TOTAL WEIGHT (PANELS & HARDWARE) 7004 Lbs**

# 28. L-SHAPE BENCH & VERTICAL PLANTER

ARTFORMS • PANEL SYSTEM



## INTERIOR VIEW

WOOD FRAME.....  
REFER TO PAGE #18 OF THE  
ARTFORMS INSTALLATION  
GUIDE

INTEGRATING 4x4" WOOD  
POST  
REFER TO PAGES #19 AND  
#20 OF THE ARTFORMS  
INSTALLATION GUIDE

4 x 4"  
WOOD POST

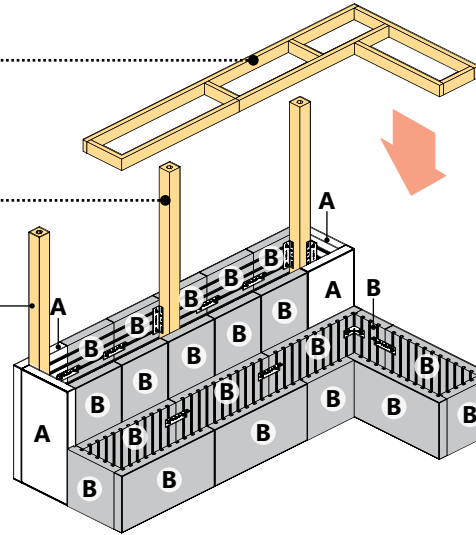

**NOTE :** Panels "B" can be replaced with panels "A" to equilibrate the pairs/layers. Panels "A" can't be replaced by the panels "B".

## REQUIRED PANELS

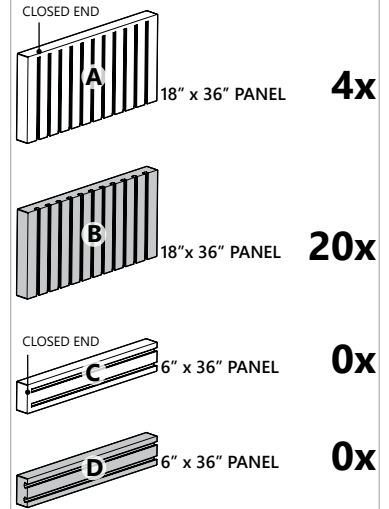

**IMPORTANT:** 18 x 36" panels are sold in pair/layer or in full pallet only. 6 x 36" panels are sold per unit or in layer or in full pallet.

## FRONT VIEW

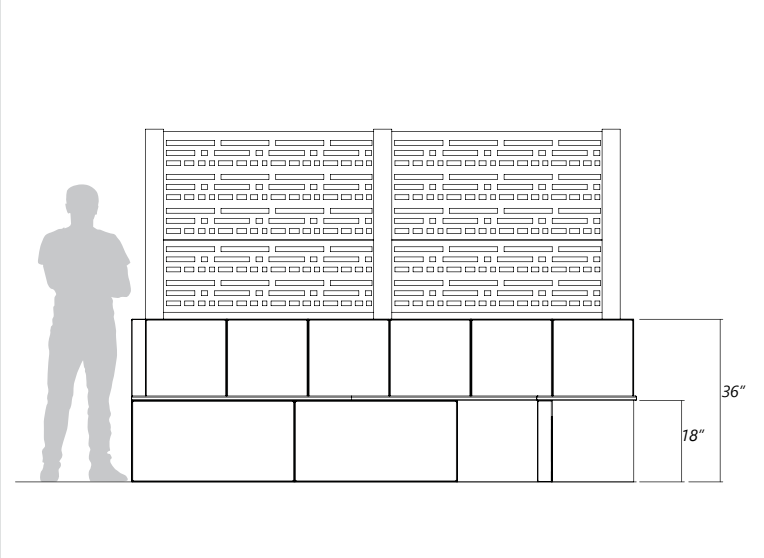

## TOP VIEW

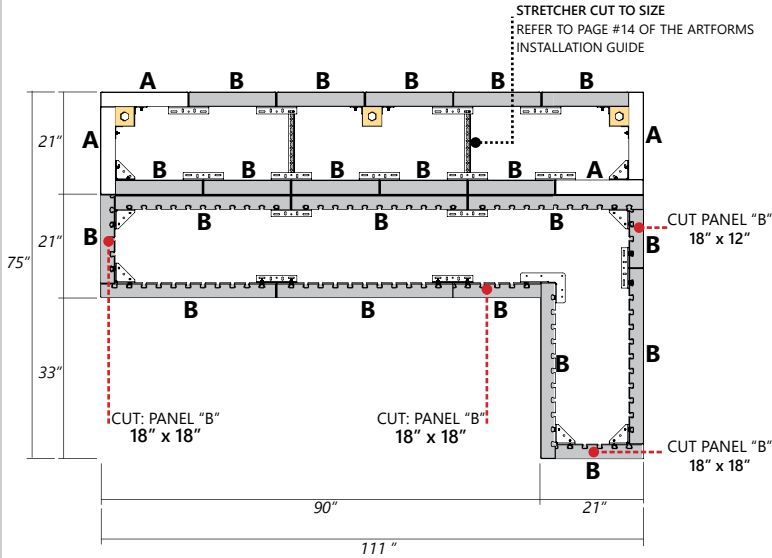

## REQUIRED HARDWARE

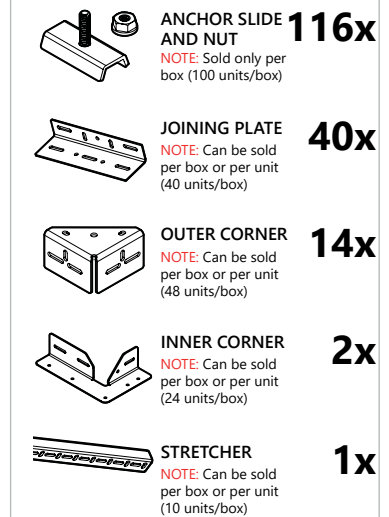

**IMPORTANT:** Refer to page 23 of the ARTFORMS INSTALLATION GUIDE about the installation of geotextile in planter box. Contact experts/engineers to validate the base preparation, the drainage, the plants & roots growth/management.

**TOTAL WEIGHT (PANELS & HARDWARE) 3615 Lbs**

# 29. BBQ WITH BENCH & VERTICAL PLANTER

ARTFORMS • PANEL SYSTEM

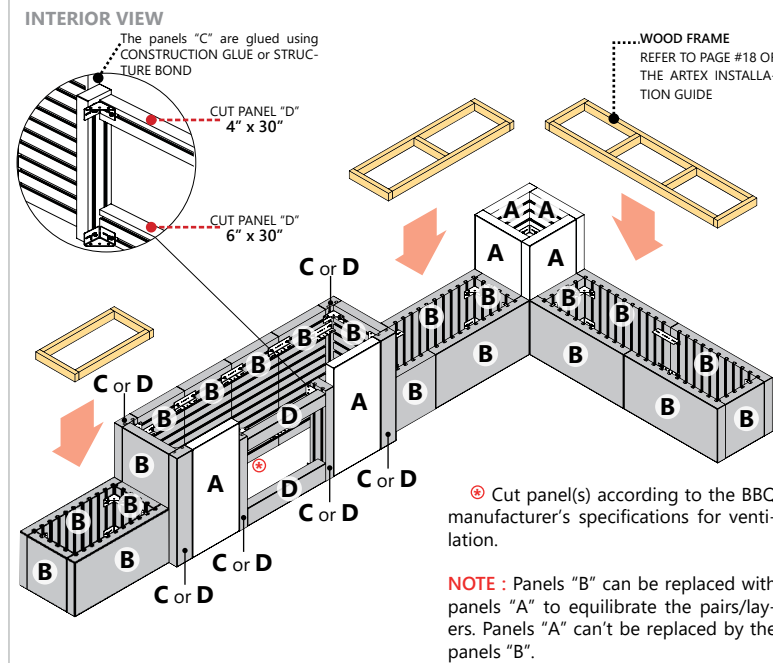

## REQUIRED PANELS

	18" x 36" PANEL	<b>6x</b>
	18" x 36" PANEL	<b>19x</b>
	6" x 36" PANEL	<b>0x</b>
	6" x 36" PANEL	<b>8x</b>

**IMPORTANT:** 18 x 36" panels are sold in pair/layer or in full pallet only. 6 x 36" panels are sold per unit or in layer or in full pallet.

## FRONT VIEW

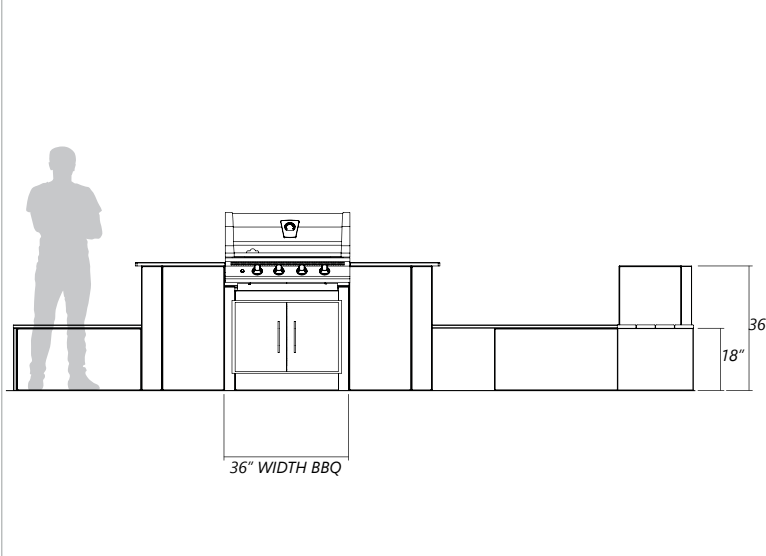

## TOP VIEW

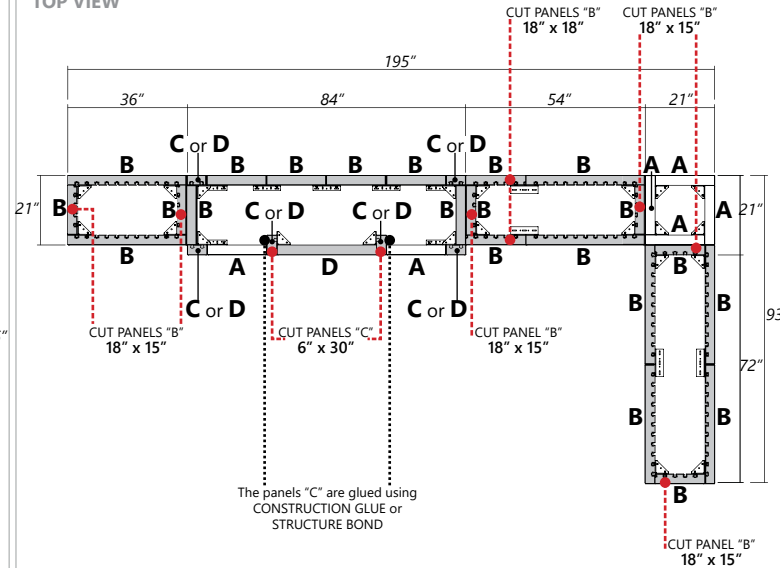

## REQUIRED HARDWARE

	<b>ANCHOR SLIDE AND NUT</b>	<b>132x</b>
	<b>NOTE:</b> Sold only per box (100 units/box)	
	<b>JOINING PLATE</b>	<b>22x</b>
	<b>NOTE:</b> Can be sold per box or per unit (40 units/box)	
	<b>OUTER CORNER</b>	<b>44x</b>
	<b>NOTE:</b> Can be sold per box or per unit (48 units/box)	
	<b>INNER CORNER</b>	<b>0x</b>
	<b>NOTE:</b> Can be sold per box or per unit (24 units/box)	
	<b>STRETCHER</b>	<b>0x</b>
	<b>NOTE:</b> Can be sold per box or per unit (10 units/box)	

**IMPORTANT:** It is recommended to follow the BBQ manufacturer's specifications for ventilation and clearances. Belgard is not responsible for the conformity of connections, clearances and ventilation. BBQ, countertop and accessories are not included. Refer to page 23 of the ARTFORMS INSTALLATION GUIDE about the installation of geotextile. Contact experts/engineers to validate the base preparation, the drainage, the plants & roots growth/management.

**TOTAL WEIGHT (PANELS & HARDWARE) 3847 Lbs**

Gas Option

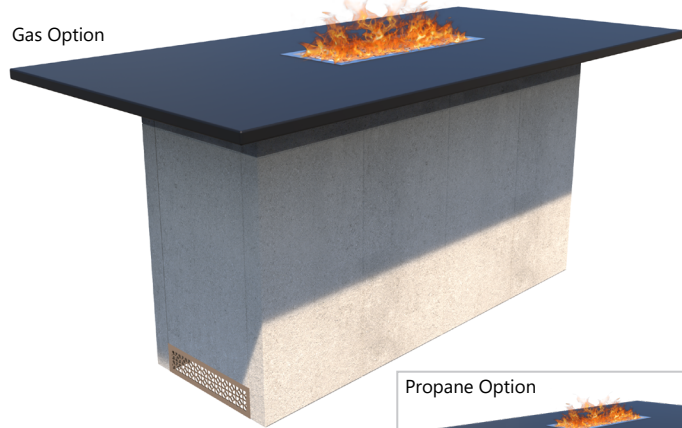

Propane Option



INTERIOR VIEW

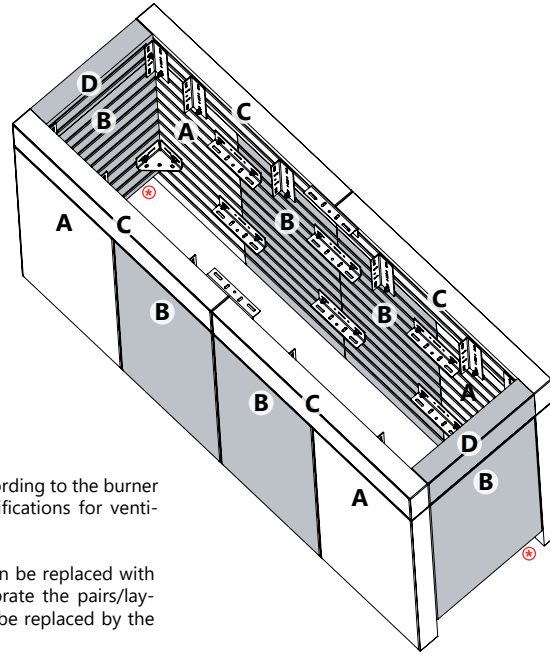

Ⓢ Cut panel(s) according to the burner manufacturer's specifications for ventilation.

**NOTE :** Panels "B" can be replaced with panels "A" to equilibrate the pairs/layers. Panels "A" can't be replaced by the panels "B".

### REQUIRED PANELS

- 18" x 36" PANEL **4x**
- 18" x 36" PANEL **6x**
- 6" x 36" PANEL **4x**
- 6" x 36" PANEL **2x**

**IMPORTANT:** 18 x 36" panels are sold in pair/layer or in full pallet only. 6 x 36" panels are sold per unit or in layer or in full pallet.

FRONT VIEW

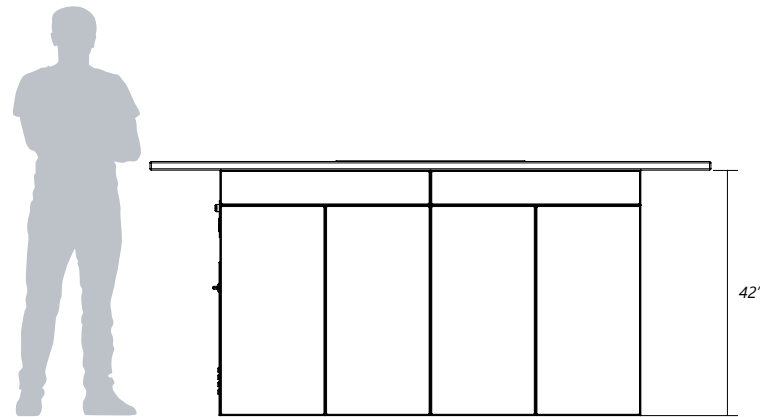

TOP VIEW

### 18" x 36" PANELS

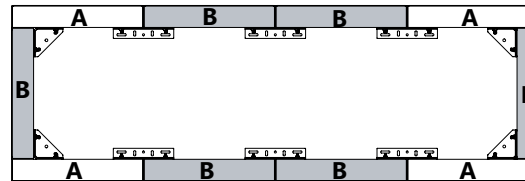

### 6" x 36" PANELS

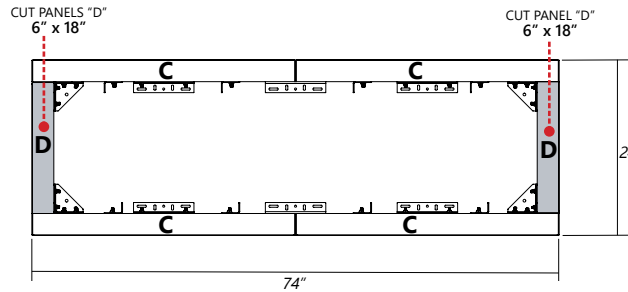

### REQUIRED HARDWARE

- ANCHOR SLIDE AND NUT **60x**  
**NOTE:** Sold only per box (100 units/box)
- JOINING PLATE **26x**  
**NOTE:** Can be sold per box or per unit (40 units/box)
- OUTER CORNER **4x**  
**NOTE:** Can be sold per box or per unit (48 units/box)
- INNER CORNER **0x**  
**NOTE:** Can be sold per box or per unit (24 units/box)
- STRETCHER **0x**  
**NOTE:** Can be sold per box or per unit (10 units/box)

**IMPORTANT:** It is recommended to follow the FIREKIT manufacturer's specifications for ventilation and clearances. Belgard is not responsible for the conformity of connections, clearances and ventilation. Burner pan, countertop and accessories are not included.

**TOTAL WEIGHT 1707 Lbs**  
(PANELS & HARDWARE)



TBD

[Consult the www.belgard.ca](http://www.belgard.ca)



[Consult the INSTALLATION GUIDE for more installation details](#)

TBD

[Consult the CALCULATOR](#)